

**SUBDIVISION AND LAND DEVELOPMENT
ORDINANCE**

TOWN OF TURIN, GEORGIA

ADOPTED August 20th, 2007

**SUBDIVISION AND LAND DEVELOPMENT ORDINANCE
TOWN OF TURIN**

TABLE OF CONTENTS

§1-1	TITLE -----	1
§1-2	PURPOSES-----	1
§1-3	DEFINITIONS -----	1
§1-4	AUTHORITY AND DELEGATION -----	14
§1-5	APPLICABILITY AND GENERAL PROVISIONS-----	14
§1-6	EXEMPTIONS FROM PLAT APPROVAL -----	15
§1-7	LOT COMBINATIONS -----	16
§1-8	BOUNDARY LINE ADJUSTMENTS -----	16
§1-9	DESIGN REQUIREMENTS FOR BLOCKS-----	17
§1-10	DESIGN REQUIREMENTS FOR LOTS -----	18
§1-11	EASEMENTS-----	20
§1-12	SURVEY MONUMENTS FOR ALL LOTS REQUIRED -----	20
§1-13	PRELIMINARY PLAT -----	21
§1-14	CONSTRUCTION PLANS AND DEVELOPMENT PERMIT -----	21
§1-15	FINAL PLAT -----	22
§1-16	DEDICATIONS OF STREETS AND PUBLIC LANDS -----	28
§1-17	SUBDIVISION IMPROVEMENT GUARANTEES -----	28
§1-18	LIMITATIONS ON MINOR SUBDIVISIONS -----	29
§1-19	STANDARDS FOR CONFIGURING NEW STREETS-----	29
§1-20	REQUIREMENTS FOR STREETS-----	31
§1-21	CURB CUTS AND ACCESS SPECIFICATIONS-----	33
§1-22	STREET LIGHTING -----	34
§1-23	STREET SIGNS -----	35
§1-24	CURBS AND GUTTERS-----	35
§1-25	SIDEWALKS-----	36
§1-26	PRIVATE STREETS-----	36
§1-27	DRAINAGE AND STORMWATER MANAGEMENT-----	39
§1-28	WATER-----	40
§1-29	SEWER -----	41
§1-30	UTILITIES -----	42
§1-31	OVERSIZING OF IMPROVEMENTS AND UTILITIES-----	42
§1-32	ADMINISTRATION -----	42
§1-33	ENFORCEMENT AND PENALTIES -----	43
§1-34	ADOPTION AND EFFECTIVE DATE-----	44

§1-1 TITLE. This ordinance shall be known and may be referred to as the Subdivision and Land Development Ordinance of the Town of Turin.

§1-2 PURPOSES. This ordinance is adopted for the following purposes:

- (a) Promote the orderly, planned, efficient, and economic development of the Town and to guide future growth in accordance with the Comprehensive Plan.
- (b) Ensure that lands subdivided are of such character that they can be used for building purposes without danger to the health or safety of residents, and to secure safety from fire, flood, or other menace.
- (c) Prevent the pollution of air, land, streams, and ponds, as well as encourage the wise use and management of natural resources throughout the Town, and preserve the topography and beauty of the community and the value of land.
- (d) Ensure the proper provision of improvements such as drainage, water, sewerage, and capital improvements such as schools, parks, playgrounds, recreational facilities, and transportation facilities.
- (e) Provide for open spaces through the most efficient design and layout of the land.
- (f) Establish procedures for the subdivision and re-subdivision of land in order to further the orderly development of land.
- (g) Provide for the proper monumenting of subdivided land and proper legal descriptions.
- (h) Help eliminate the costly maintenance problems that develop when streets and lots are established without proper consideration given to various public purposes.
- (i) Facilitate and inform lot purchasers who generally lack the specialized knowledge needed to evaluate subdivision improvements and design.

§1-3 DEFINITIONS. When used in these regulations the following words and phrases shall have the meaning given in this section. Terms not defined here shall have their customary dictionary definitions where not inconsistent with the context. The Town Council's interpretation shall be final as to the meaning of any definition, statement, requirement, symbol, and/or abbreviation used in connection with these regulations and/or their application.

Access: A way or means of approach to provide physical entrance to a property.

Access easement: An easement devoted to vehicular access which affords a principal means of access to abutting property or properties, but which is not necessarily open to the general public and which is not necessarily improved to standards of the Town.

Agricultural facility: Includes, but is not limited to, any land, building, structure, pond, impoundment, appurtenance, machinery, or equipment which is used for the commercial production or processing of crops, livestock, animals, poultry, honeybees, honeybee products, livestock products, poultry products, timber, forest products, or products which are used in commercial aquaculture. Such term does not include any farm labor camp or facilities for migrant farm workers.

Agricultural operation: Those practices involving the establishment, cultivation, or harvesting of products of the field or orchard; the preparation and planting of pasture land; farm ponds; dairy operations; livestock and poultry management practices; the construction of farm buildings; The plowing, tilling, or preparation of soil at an agricultural facility; The planting, growing, fertilizing, harvesting, or otherwise maintaining of crops; The application of pesticides, herbicides, or other chemicals, compounds, or substances to crops, weeds, or soil in connection with the production

of crops, timber, livestock, animals, or poultry; The breeding, hatching, raising, producing, feeding, keeping of livestock, hogs, equines, chickens, turkeys, poultry or other fowl normally raised for food, mules, cattle, sheep, goats, dogs, rabbits, or similar farm animals for commercial purposes, but not the regular slaughtering, or processing of such animals; The production and keeping of honeybees, the production of honeybee products; The production, of eggs or egg products; The manufacturing of feed for poultry or livestock; The rotation of crops, including without limitation timber production; Commercial aquaculture; and the application of existing, changed, or new technology, practices, processes, or procedures to any agricultural operation. Agricultural operation does not include a roadside stand or agricultural processing.

Alley: A strip of land dedicated to public use providing vehicular and pedestrian access to the rear of properties which abut and are served by a road or street.

Block: An area of land within a subdivision that is entirely surrounded by public streets, public lands, railroad rights-of-way, watercourses, or other well defined and fixed boundaries. (See Figure).

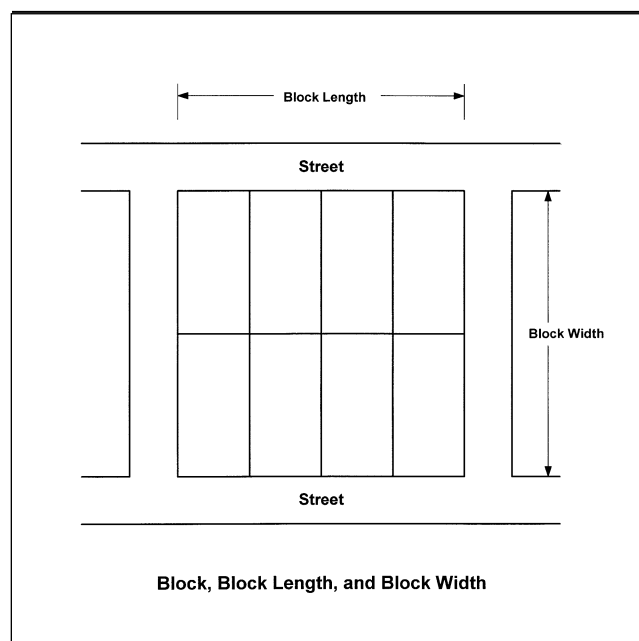

Comprehensive plan: Any plan adopted by the Town Council, or portion of such plan or plans. This definition shall be construed liberally to include the major thoroughfare plan, master parks and recreation plan, or any other study, document, or written recommendation pertaining to subjects normally within the subject matter of a Comprehensive Plan as provided by the Georgia Planning Act of 1989, if formally adopted by the local governing body.

Conservation: The management of natural resources to prevent waste, destruction, or degradation.

Conservation areas, primary: Any property qualifying as conservation use property under O.C.G.A. Section 48-5-7.4; and any steep mountain slopes, floodplains, wetlands, water bodies, upland buffers around wetlands and water bodies, critical wildlife habitat, and sites of

historic, cultural, or archaeological significance, located outside of building envelopes and lots established for building purposes.

Conservation areas, secondary: Prime farmland, natural meadows, mature woodlands, farm fields, localized aquifer recharge areas, and lands containing scenic views and sites, located outside of building envelopes and lots established for building purposes.

Conservation easement: A legally enforceable agreement between a property owner and the holder of the easement, in a form acceptable to the Town Attorney and recorded in the office of the Clerk of Superior Court of Coweta County. A conservation easement restricts the existing and future use of the defined tract or lot to conservation use, agriculture, passive recreation, or other use approved by the Town Council and prohibits further subdivision or development. Such agreement also provides for the maintenance of open spaces and any improvements on the tract or lot. Such agreement cannot be altered except with the express written permission of the easement holder and any other co-signers. A conservation easement may also establish other provisions and contain standards that safeguard the tract's or lot's special resources from negative changes.

Conservation subdivision: A subdivision where open space is the central organizing element of the subdivision design and that identifies and permanently protects all primary and all or some of the secondary conservation areas within the boundaries of the subdivision.

Contiguous common parcels: Parcels adjoining or touching other land at a common point and having a common owner, regardless of whether or not portions of the parcels have separate tax lot numbers, or were purchased in different land lots, or were purchased at different times.

Cross-section: A profile of the ground surface perpendicular to the centerline of a road, stream, or other feature.

Cul-de-sac: A dead-end street of limited length having a primary function of serving adjoining land, and constructed with a turnaround at its end.

Cul-de-sac, temporary: A nonpermanent vehicular turn around located at the termination of a street or alley.

Curb radius: The curved edge of a road at road intersections.

Deceleration lane: An added roadway lane, of a specified distance and which may include a taper, as approved by the Land Use Officer that permits vehicles to slow down and leave the main vehicle stream.

Dedication: The deliberate appropriation of land by an owner for any general and public use or purpose, reserving to himself no other rights than such as are compatible with the full exercise and enjoyment of the public uses to which the property has been devoted.

Dedication plat: A plat that indicates property to be dedicated for public right-of-way or land for public use.

Detention: The temporary restraining of storm water on-site.

Detention pond: A pond or pool used for the temporary storage of storm water runoff and which provides for the controlled release of such storm water.

Development: Any manmade change on improved or unimproved real estate, including but not limited to, buildings, structures, mining, dredging, filling, grading, paving, excavation, drilling, or permanent storage of materials or equipment.

Development plan: Any plan containing substantial information required to be filed by this ordinance, which shows how the property to be affected by the development will be changed and improved in a specific manner, including the installation of roads and utilities and the erection of buildings and structures, among other specific requirements.

Drainage structure: A device composed of a virtually non-erodible material such as concrete, steel, plastic or other such material that conveys water from one place to another by intercepting the flow and carrying it to a release point for storm-water management, drainage control, or flood control purposes.

Easement: A grant of one or more of the property rights by the property owner to and/or for use by the public, a corporation, or another person or entity. (See Figure)

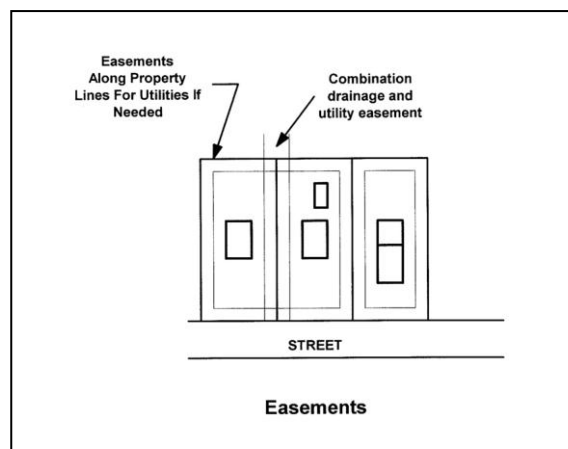

Escrow account: A type of subdivision improvement guarantee where the subdivider deposits either cash, a note, a bond, or some other instrument readily convertible to cash for specific face value specified by the Land Use Officer to cover the costs of required improvements.

Excavation: A portion of land surface or area from which earth has been removed or will be removed by excavation; the depth below original ground surface to excavated surface. Also known as "cut."

Fill: A portion of land surface to which soil or other solid material has been added; the depth above the original ground.

Final plat: The final drawing of a subdivision and, as applicable, dedication, prepared for filing for record with the Clerk of the Coweta County Superior Court, and containing all elements and requirements set forth in this ordinance.

Fire flow: The flow of water required to extinguish the largest probable fire served by a water facility.

Forestry: An operation on a tract or parcel of land involving the growing, conserving, and managing of forests and forest lands (includes the term "silviculture"). Forestry operations or practices include the raising and harvesting of timber, pulp woods and other forestry products for commercial purposes. Incidental uses to forestry include the erection of accessory structures and improvements normally associated with timber production, including but not limited to storage buildings, the construction of roads, insect and disease control, fire protection, and may include the temporary operation of a sawmill and/or chipper to process the timber cut from the parcel or parcels. This term does not include the cutting of timber associated with approved land development. This definition does not include processing of timber into finished or semi-finished products or other than temporary storage of logs.

Gated community: Residential areas containing lots and that restrict access to roads and spaces. Gates can include guard houses, electronic arms operated by card, codes, or remote control devices. Visitors must stop to be verified for entry.

Grade, natural: The existing grade or elevation of the ground surface that exists or existed prior to man-made alterations, such as grading, grubbing, filling, or excavating.

Gradient: The rate of vertical change between two distance points, determined by dividing the vertical distance by the horizontal distance (i.e., rise over run).

Grading: Altering the shape of ground surfaces to a predetermined condition; this includes stripping, cutting, filling, stockpiling and shaping or any combination thereof and shall include the land in its cut or filled condition.

Greenway: A linear park or open space conservation area that provides recreational opportunities, pedestrian and/or bicycle paths, and/or conservation of open spaces or natural areas.

Habitat for endangered or threatened species: An area verified by the Georgia Department of Natural Resources as; 1) actually containing naturally-occurring individuals of a species that has been listed as endangered or threatened under the Federal Endangered Species Act, as amended, and, 2) being likely to support the continued existence of that species by providing for a significant portion of that species' biological requirements, and that meets the definition of "natural conditions" as defined by this ordinance.

Half street: A portion of the ultimate width of a road or street where the remaining portion of the road or street shall be provided at a future date.

Home owners association: An organization formed for the maintenance and operation of the common areas of a development, where membership in the association is automatic with the purchase of a dwelling unit or lot within the development, with the ability to legally assess each owner of a dwelling unit or lot and which has authority to place a lien against all dwelling units and lots within the development.

Impact: The effect of any direct man-make actions or indirect repercussions of man-made actions on existing physical, social, or economic conditions.

Improvements: The physical addition and changes to land that may be necessary to produce usable, desirable and acceptable lots or building sites.

Intra-family land transfer: A division of land within one or more specified land use districts that creates at least one additional lot but not more than four additional lots, each of which is not less than one acre nor more than five acres in size, where each and every lot within the subdivision is conveyed to the children, spouse and children, surviving heirs, in-laws, or immediate relatives of the property owner, or some combination thereof, and where no more than one (1) lot in the subdivision is deeded to any one individual. Each lot created in an intra-family land transfer is conveyed by final plat, and each lot meets the requirements of this ordinance for access, lot size, and lot width. This definition shall not include or authorize any land subdivision that involves or will involve the creation of lots for sale or otherwise involves a property transfer for money, tangible or intangible personal property, real property exchanges, or other conveyances for consideration.

Land suitability analysis: A method used by land planners, in preparing land use plans at a community- wide scale or land plans at a site development scale, to evaluate the fitness of land for various uses based at least partially on environmental criteria. The end product of land suitability analysis is typically a map or set of maps depicting the appropriateness of land areas for various land uses.

Land trust: A private, nonprofit conservation organization formed to protect natural resources, such as productive farm or forest land, natural areas, historic structures, and recreational areas. Land trusts purchase and accept donations of conservation easements. They educate the public about the need to conserve land and some provide land-use and estate planning services to local governments and individual citizens.

Land Use Officer: The official, or person designated by the Town Council of the Town of Turin to whom the responsibilities normally associated with this title have been delegated. In the absence of such designation, the Town Council shall perform the duties of the Land Use Officer.

Letter of credit: A type of subdivision improvement guarantee whereby a subdivider secures an instrument from a bank or other institution or from a person with resources sufficient to cover the cost of improvements required by the Town. The instrument pledges the creditor to pay the cost of improvements in case of default by the subdivider.

Lot: A portion or parcel of land separated from other portions or parcels by description (such as on a subdivision plat of record or a survey map or plat) or described by metes and bounds, and which could be or is intended for use, transfer of ownership, or for building development, or any combination thereof. The word "lot" shall not include any portion of a dedicated right-of-way.

Lot area: The total horizontal area within the lot lines of a lot, exclusive of public road right-of-ways or private road or access easements, where they exist.

Lot, corner: A lot abutting upon two or more streets at their intersection.

Lot, depth: The average horizontal distance between the front and rear lot lines.

Lot, double frontage: A lot other than a corner lot that has frontage upon two or more streets that do not intersect at a point abutting the property.

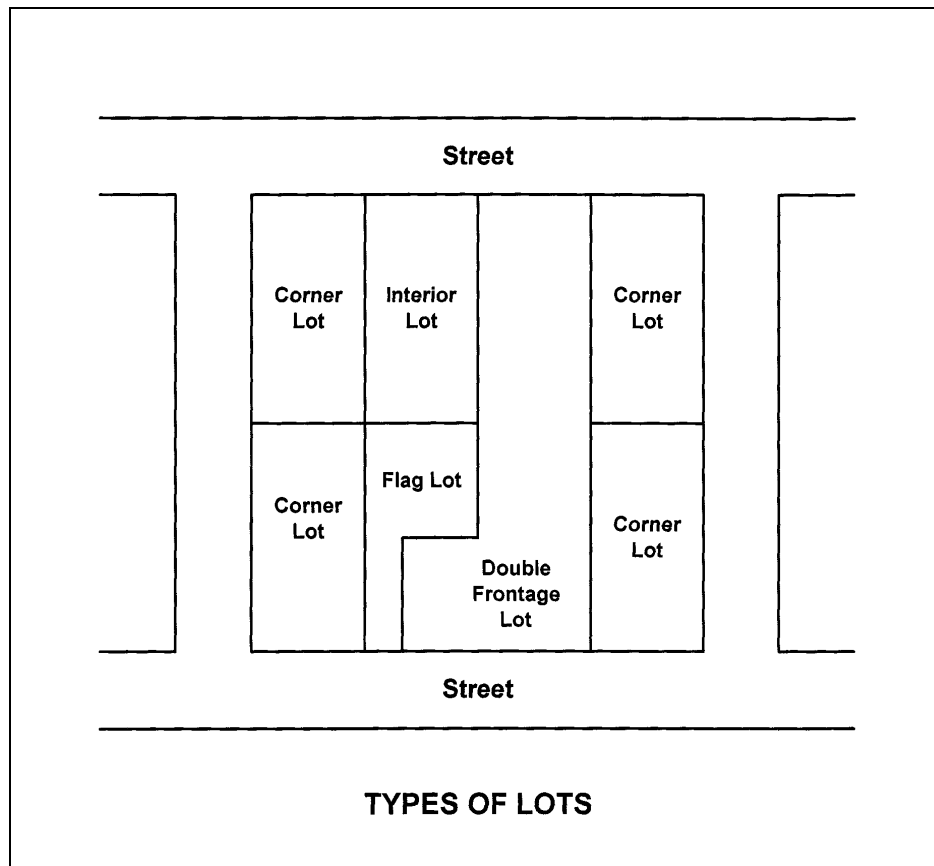

Lot, flag: A tract or lot of land of uneven dimensions in which the portion fronting on a street is less than the required minimum width required for construction of a building or structure on that lot. Such lots have elongated access from the road and a conventionally proportioned building site at the rear of the lot.

Lot, through: See "Lot, double frontage".

Lot frontage: The width in linear feet of a lot where it abuts the right-of-way of any street.

Lot of record: A lot which is part of a subdivision approved in accordance with land subdivision requirements, a plat of which has been lawfully recorded in the records of the Clerk of the Coweta County Superior Court; or a parcel of land, the deed of which was lawfully recorded in the same office prior to adoption of this ordinance.

Lot width: The shortest distance between side lot lines measured at the regulatory/required front building line, or in the absence of a front building line regulation, the distance between side lot lines measured at the front line of the building located or intended to be located on the lot.

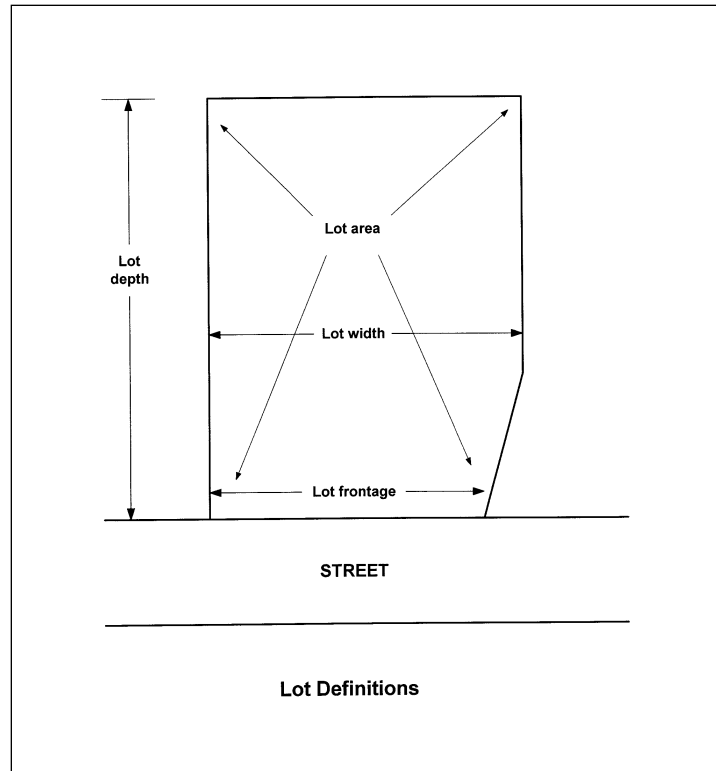

Mayor: The Mayor of the Town of Turin.

Metes and bounds: A system of describing and identifying land by distances or measures (metes) and bearings or direction (bounds) from an identifiable point of reference, such as a monument or other marker or the corner of intersecting roads.

Model home: A principal residential building, temporarily open to viewing by prospective homebuyers, on property containing or proposed to contain a residential subdivision, and which may also be used temporarily as real estate sales office for lots in the residential subdivision.

Mortgage Lot: A lot which is created for the primary or sole purpose of meeting the requirement of a bank or lending institution for a loan or mortgage in cases where property descriptions must be smaller than the total acreage of the tract on which the principal building that is the subject of the loan is located.

Natural conditions: The flora, fauna, soil and water conditions that would develop on a specific tract of land if all human interference were to be removed. The tract of land must have been undisturbed for a sufficient period of time for natural processes to dominate the tract. This period of time will vary among environments.

Off-site: Beyond the boundaries of the property in question.

On-site: Within the boundaries of the property in question.

Open space: Any combination of primary conservation areas and secondary conservation areas, as defined, that together form a permanent, undivided or relatively undivided,

undeveloped area. As much as 25 percent of the open space may be devoted to active recreational facilities, as defined. Easements for electric transmission lines or any other above ground improvement shall not be considered open space. Stormwater management features, such as lakes, ponds, and ways, may be considered open space at the discretion of the Land Use Officer, provided that such areas are designed and maintained in a manner that contributes to open space and the aesthetics of the subdivision.

Open space, public: An area within a development or subdivision designed and intended for the use and enjoyment of all residents or for the use and enjoyment of the public in general.

Original tract: A unit of land which the owner holds under single or unified ownership, or which the owner holds controlling interest on the effective date of this ordinance, where all land abutting said tract is separately owned by others, not related to or associated by business partnership with the owner.

Package treatment plant: A sewage treatment facility, usually privately operated, typically having a treatment capacity of less than one million gallons per day. In most cases, a package treatment plant is considered a temporary means of wastewater treatment until connection to a public sanitary sewerage system is available.

Pavement width: The width of a given lane, road, or other road pavement, measured from back-of-curb to back-of-curb, or to the edge of pavement where no curbs are required or exist.

Pedestrian way: A public right-of-way or private easement across a block or within a block to provide access for pedestrians and which may, in addition to providing pedestrian access, be used for the installation of utility lines.

Performance bond: A type of subdivision improvement guarantee in the form of a bond, secured by the subdivider from a bonding company, in an amount specified by the Land Use Officer to cover the costs of required improvements, and payable to the Town. The Town may call in the performance bond in the event the subdivider defaults on required improvements.

Performance guarantee: Any financial deposit or other security that may be accepted by the Town as a guarantee that improvements required as part of an application for subdivision or land development are satisfactorily completed in conformance with approved plans.

Person: A natural human being, estate, association, firm, partnership, corporation, or other legal entity.

Potable water: Water that is suitable for human consumption, human contact, or in the preparation of foods for human consumption.

Preliminary plat: A tentative drawing or map of a proposed subdivision. A preliminary plat is the basis for the approval or disapproval of the general layout of a land subdivision.

Planned unit development: A form of development usually characterized by a unified site design for a number of housing units, clustered buildings, common open space, and a mix of building types and land uses in a slightly more dense setting than allowable on separate lots.

Planning Commission: The Town of Turin Planning and Zoning Commission.

Professional engineer: An engineer duly registered or otherwise authorized by the State of Georgia to practice in the field of civil engineering.

Protective covenants: Contracts made between private parties as to the manner in which land may be used, with the view toward protecting and preserving the physical and economic integrity of any given area.

Recreation, active: Leisure activities that are facility oriented, such as swimming pools, tennis courts, and ball fields.

Recreation, passive: Leisure activities that are natural resource oriented, such as hiking trails, conservation areas, and nature preserves.

Registered land surveyor: A surveyor duly registered or otherwise authorized by the State of Georgia to practice in the field of land surveying.

Reservation: The designation by plat or deed of a certain area reserved for possible future public purposes. A reservation does not transfer title of the reserved area to the public unless the local governing body accepts the area for public purposes.

Resubdivision: The act of changing an existing lot created by a plat and recorded in the Office of the Clerk of Superior Court of Coweta County, Georgia.

Reserve strip: A strip of land across the end of, or along the edge of, a street, alley, or lot for the purpose of controlling access which is reserved or held until future street extension or widening.

Retaining wall: A wall or similar structure used at a grade change to hold soil on the up-hillside from slumping, sliding, or falling.

Retention: The permanent maintenance of storm water on-site.

Retention pond: A pond or pool used for the permanent storage of storm water runoff.

Right-of-way: A strip of land acquired by reservation, dedication, forced dedication, prescription, or condemnation and intended to be occupied by a road, crosswalk, railroad, electric transmission line, oil or gas pipeline, water line, sanitary storm sewer, or other similar use; Generally, the right of one to pass over the property of another.

Right-of-way, public: That area, distinguished from an easement or private road right-of-way, which is owned in fee-simple title by the local governing body or other government, for the present or future use of roads, roads and highways, together with its drainage facilities and other supporting uses and structures.

Right-of-way, private: That area, distinguished from an access easement or public right-of-way, dedicated to property owners of the subdivision involved or to other individuals, and which affords permanent access to abutting property or properties. A private right-of-way is distinguishable from a public road right-of-way in that maintenance and ownership of the road and accessory improvements is by private individuals or a private association rather than the local governing body or another governmental entity.

Riprap: Rocks, rubble, or stones, irregularly shaped and at least six inches in diameter, used for erosion control and soil stabilization.

Scenic views and sites: Those geographic areas containing visually significant or unique natural features, as identified in the Comprehensive Plan, or by other reasonable means.

Sensitive natural areas: Any area, as identified now or hereafter by the Department of Natural Resources, which contains one or more of the following: habitat, including nesting sites, occupied by rare or endangered species; rare or exemplary natural communities; significant landforms, hydroforms, or geological features; and/or other areas so designated by the Department of Natural Resources that are sensitive or vulnerable to physical or biological alteration.

Septic tank: An approved watertight tank designed or used to receive sewage from a building sewer and to affect separation and organic decomposition of sewerage solids, and discharging sewage effluent to an absorption field or other management system.

Sewer: An artificial and usually subterranean conduit designed to carry off sewage and/or water. The term includes any pipe, manhole, connection, or other appurtenances thereto, located in a public right-of-way or easement that is designed to transport sewage and/or water.

Sewer, sanitary: A sewer that carries sewage and residential, commercial or industrial waste.

Sewer, storm: A sewer that carries storm, surface, and ground water drainage but excludes sewage and residential, commercial, and industrial wastes.

Sidewalk: A hard-surfaced pedestrian access area adjacent to or within the right-of-way of a public road.

Site plan: A drawing of a multi-family residential, institutional, office, commercial, or industrial development, showing the general layout of a proposed development including among other features the location of buildings, parking areas, and buffers and landscaping. The site plan is the basis for the approval or disapproval of the general layout of a development in the case of a multiple-family residential, institutional, office, commercial, or industrial development.

Sight visibility triangle: The areas at the corners of an intersection of two roads, or at the intersection of a road and any driveway, which may vary based on type of road involved, that are to be kept free of vegetation, trees, shrubs, ground covers, berms, fences, buildings, structures, or other materials or objects that may impair or impede a person's ability to observe other persons or traffic on the adjacent intersecting roadway and/or driveway.

Slope: Degree of deviation of a surface from the horizontal, usually expressed in percent or degree; the ratio of the difference in elevation between two points on the ground, and the horizontal distance between these two points. For purposes of determining steep slopes, slopes shall be measured between two points on the ground separated by 500 feet or more.

Steep slopes: Lands with slopes of at least 35 percent, as indicated in the Comprehensive Plan of the Town, or which can be calculated with aid of a United States Geological Survey 1:24,000, 7.5 minute quadrangle topographic map or other available topographic information.

Street: Any vehicular way, other than an alley, that:

- (a) Is an existing federal, state, county or municipal roadway;
- (b) Is constructed as shown upon a plat approved pursuant to law and is open to vehicle travel;
- (c) Is constructed and open to vehicle travel as approved by other official action of the Town Council; or
- (d) Is constructed and open to vehicle travel and shown on a plat duly filed and recorded in the Clerk's Office, Coweta County Superior Court prior to the effective date of this ordinance. Land between the street lines, whether improved or unimproved, shall be considered part of the street.

Street, collector: Unless otherwise defined by the Major Transportation Plan or Comprehensive Plan, a collector street is a public street whose function is to collect traffic from neighborhoods and local streets and which connects to another public street of equal or greater classification. A collector also may provide direct access to adjacent properties.

Street, dead end: A street having one end open for access to another street and the other end being abruptly terminated with no turnaround.

Street, local: Unless otherwise defined in the Major Transportation Plan or Comprehensive Plan, any public street, except an alley, collector, or arterial, and which has a primary function to provide direct access to adjoining properties and which serves a limited area only, usually a single land subdivision.

Street, major arterial: Unless otherwise defined by the Major Transportation Plan or Comprehensive Plan, a major arterial street is a street connecting two or more towns or communities, connecting two highways of equal or greater capacity, or serving as the primary access to a large land area. A major arterial may also serve a large traffic generator (e.g., an industrial area) and perform a secondary function of providing local access.

Street, marginal access: A residential street parallel and adjacent to a major thoroughfare and which provides access to abutting properties with protection from through-traffic.

Street, private: A road or street that has not been accepted for maintenance by the Town and that is not owned and maintained by a state, county, city, or another public entity.

Subdivider: Any person, as defined by this ordinance, who undertakes the subdivision of land, and any person having such a proprietary interest in land to be subdivided as will authorize the maintenance of proceedings to subdivide such land under this ordinance, or the authorized agent of such person.

Subdivision: A division of a tract or parcel of land into two or more lots, building sites, or other divisions for the purpose of sale or building development, whether immediate or future, including all division of land involving the dedication of a new street or a change in existing streets. The word "subdivision" includes re-subdivision and, when appropriate to the context, relates either to the process of subdividing or to the actual land or area which is subdivided.

Subdivision, minor: A subdivision of four or fewer lots, which does not involve the construction of a new public or private street. Because minor subdivisions do not involve the construction of a new public or private street, they are processed by the Town Council as final plat applications that do not require preliminary plat approval. Any improvements to an existing public street abutting the tract proposed for minor subdivision, or the installation of utilities along said existing public road, as may be required to comply with this ordinance, shall be done according to plans and permit requirements of this ordinance, but said requirements shall not subject the minor subdivision to the requirements for a major subdivision as specified in this ordinance.

Subdivision, major: The division of a tract or parcel of land into four or more lots which may or may not involve the construction of a new public or private street; or any subdivision that involves the construction of a new public or private street. Because major subdivisions involve construction of a new public or private street or the upgrade of an existing private access way to Town standards, construction plans and development permits are required, and major subdivisions are therefore processed in multiple steps including preliminary plat approval (unless specifically exempted), approval of construction plans and issuance of development permits, and final plat approval.

Town: The Town of Turin, Georgia.

Town Council: The Mayor and Town Council of the Town of Turin. The governing body of the Town of Turin.

Trail: A way designed for and used by equestrians, pedestrians, and/or cyclists using bicycles. No motorized vehicles are allowed.

Tree: Any self-supporting, woody perennial plant usually having a single trunk diameter of three (3) inches or more which normally attains a mature height of a minimum of fifteen (15) feet.

Tree, flowering ornamental: A tree that produces seasonal flowers and blossoms and is used primarily for aesthetic or ornamental purposes (e.g., flowering dogwood; eastern redbud).

Tree, hardwood: Any leaf-bearing (not needle-bearing) tree that is not coniferous (cone bearing). This definition is based on the colloquialism, and does not necessarily reflect any true qualities of the tree.

Tree, shade: A broadleaf tree having an average height at maturity of at least 20 feet and having a broad spread relative to its height (excluding trees with pyramidal, conical, or columnar crowns) and a dense canopy, so as to provide shade to structures or parking areas in the summer months.

Undergrounding: The placement of utility lines below ground, with the removal of above-ground poles, wires and structures as applicable.

Utility: Public or private water or sewer piping systems, water or sewer pumping stations, electric power lines, fuel or gas pipelines, telephone lines, roads, cable telephone line, fiber optic cable, driveways, bridges, river/lake access facilities, storm water systems and drainage ways, and railroads or other utilities identified by the Town. As appropriate to the context, the term "utility" may also include all persons, companies, or governmental agencies supplying the same.

Vacation: The termination of, or termination of interest in, an easement, right-of-way, or public dedication of land.

Variance: A grant of relief from the strict requirements of this ordinance which permits construction in a manner that would otherwise be prohibited by this ordinance; a minimal relaxation or modification of the strict terms of this ordinance as applied to specific property when, because of particular physical surroundings, shape, or topographical condition of the property, compliance would result in practical difficulty; or a grant of relief from the strict requirements of this ordinance due to a proposed project not being able to meet policies and objectives specifically identified in the Comprehensive Plan.

Vicinity map: A map, not necessarily to scale, showing the general location of the proposed subdivision or land development in relation to major roads, government boundaries, and/or natural features.

Well: A hole or shaft excavated, bored, drilled, dug, or driven to tap an underground supply of water.

Zoning Regulations: The zoning regulations enacted by the Town Council.

§1-4 AUTHORITY AND DELEGATION

§1-4.1 Authority. These regulations are adopted pursuant to powers vested in towns by the State of Georgia Constitution, home rule powers, state administrative rules for the adoption and implementation of Comprehensive Plans, and the protection of vital areas of the State.

§1-4.2 Powers of the Planning Commission. The Planning Commission is vested with the authority to review for conformity to the requirements of this ordinance, and to make reports and recommendations to the Town Council on preliminary and final plats of major and minor subdivisions and re-subdivisions, lot combination plats, lot line adjustments, dedication plats, constructions plans, and variances from the requirements of this ordinance.

§1-4.3 Powers of the Town Council. The Town Council is the authority to review, approve, conditionally approve or disapprove proposed subdivisions and land development improvements in accordance with the requirements of this ordinance, and to administer, interpret, and enforce the provisions of this ordinance.

§1-5 APPLICABILITY AND GENERAL PROVISIONS

§1-5.1 Applicability. This ordinance shall apply to all real property within corporate limits of the Town of Turin.

§1-5.2 Land is One Tract Until Subdivided. Until property proposed for subdivision has received final plat approval and been properly recorded, the land involving the subdivision shall be considered as one tract, or as otherwise legally recorded.

§1-5.3 Subdivision of Land. No person shall sell, advertise, or offer to sell, by deed, map, plat or other instrument, any parcel of land not subdivided under the requirements of this ordinance. It shall be unlawful for any person to transfer or sell land by reference to, or by exhibition of, or by other use of, a plat of a land subdivision that has not been approved and recorded in accordance with the requirements of this ordinance. The description of such land by metes and bounds in the instrument of transfer shall not exempt the transaction. No plat of land subdivision shall be entitled to be recorded in the Office of the Clerk of the Superior Court of Coweta County, and it shall be unlawful to record such a plat of land subdivision, unless and until it shall have been approved in accordance with the requirements of this ordinance.

§1-5.4 Development or Improvement of Land. No person shall disturb or develop land or engage in development except in accordance with this ordinance. It shall hereafter be unlawful for any person to disturb or develop any land until construction plans submitted and development permit, if required, has been approved by the Town Council in accordance with this ordinance. No person shall begin construction of any improvement on any lot prior to the approval of a preliminary plat, if required by this ordinance, nor prior to approval of a development plan for said improvement as required by this ordinance. The Town Council shall not authorize or permit the clearance of trees and vegetative materials, except for grubbing, outside approved construction limits.

§1-5.5 Preliminary Plat and Plans Required Prior to Construction. No person shall commence construction of any improvements on any lot, prior to the approval of a preliminary plat if required by this ordinance, nor prior to approval of construction plans and engineering plans for said improvements are approved as required by this ordinance.

§1-5.6 Building and Other Permits. No building permit or certificate of occupancy, if required by the local government, shall be issued for a building, structure, or use, nor shall any excavation, grading, or land disturbance applications be approved, on any parcel of land regulated by this ordinance that has not been approved in accordance with the provisions of this ordinance.

§1-5.7 Public Streets and Lands. No land dedicated as a public street or for other public purpose shall be opened, extended, or accepted as a public street or for other public land unless such improvements are constructed in accordance with the specifications of this ordinance and said land and/or improvements are formally approved and accepted as public improvements by the Town Council in accordance with procedures established in this ordinance.

§1-5.8 Appeals. Any person aggrieved by an interpretation or decision of the Planning Commission or other official responsible for the administration of this ordinance may file an appeal to the Town Council. Any person aggrieved by any interpretation or decision of the Town Council shall have the right of certiorari to the Superior Court within thirty (30) days after the decision of the Town Council is rendered.

§1-5.9 Special Review of Subdivisions along State Routes. No subdivision plat containing land that abuts a state route shall be approved until such plat has been submitted for review and comment by the Georgia Department of Transportation, in accordance with the provisions of O.C.G.A. 32-6-151. When the Town receives such a plat, it shall submit two copies of the proposed subdivision plat to the Georgia Department of Transportation if such proposed subdivision includes or abuts on any part of the state highway system. The Georgia Department of Transportation, within 30 days of receipt of the plat, shall recommend approval and note its recommendation on the copy to be returned to the Town Council or recommend rejection. Failure of the Georgia Department of Transportation to act within this 30 day period shall constitute approval. If the plat is recommended for rejection, the reasons for rejection and requirements for approval shall be given the Town Council in writing. A recommendation for rejection shall be binding on the Town Council unless the Town Council, by official action recorded in its minutes, overrules the recommendation for rejection.

§1-6 EXEMPTIONS FROM PLAT APPROVAL

The following types of land subdivisions, transfers, and sales are specifically exempted from the plat approval requirements of this ordinance; provided, however, that such exemptions shall not apply to land development requirements and improvement requirements of this ordinance.

- (a) The creation and sale of cemetery plots.

- (b) The sale of lots consistent with previously approved and recorded plats or deeds.
- (c) The creation of leaseholds for space within a multiple-occupancy building or the division of property into leaseholds for commercial, industrial, or institutional use.
- (d) The creation of leaseholds for the agricultural use of property where the use does not involve the construction of a building to be used as a residence or for other purposes not directly related to agricultural use of the land or crops or livestock raised thereon.
- (e) Any division of land to heirs through a judicial estate proceeding, or any division of land pursuant to a judicial partition, or any division of land occurring from the foreclosure of a deed of trust; provided, however, that such exemption shall not require the Town to issue permits if the resulting lots or parcels fail to meet any applicable regulations of the local jurisdiction concerning lot size, lot width, and other dimensional requirements.
- (f) Intra-family land transfers and mortgage lots, as defined by this ordinance.

§1-7 LOT COMBINATIONS

An existing lot line forming the boundary between two conforming plated lots located within the same subdivision or a lot line between lots or parcels that have merged to form one building lot may be removed or eliminated through a final plat revision process which conforms to the requirements of this ordinance. In the case no final plat applies to the subject lots or parcels, a boundary survey and plat depicting all lots involved in the lot combination shall be required to be approved by the Town Council and recorded as a final plat. Such combination plat shall be titled with the same name as that of the original subdivision, if applicable, and shall indicate thereon that the replat is for the purpose of removing the lot lines between specific lots. (See Figure).

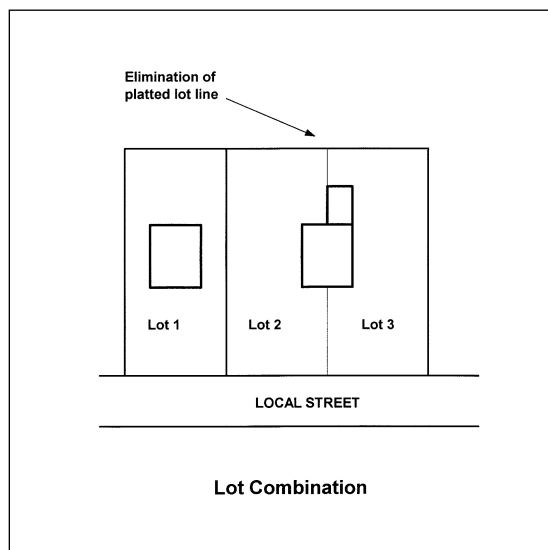

§1-8 BOUNDARY LINE ADJUSTMENTS

One or more existing lot lines forming boundaries between conforming plated lots located within the same subdivision, or one or more lot lines between abutting lots or parcels may be adjusted through a final plat revision process that requires the approval of the Town Council and recording of a plat meeting the specifications of a final plat. In the case no final plat applies to

the subject lots or parcels, a boundary survey and plat of the entire lots involved in the boundary line adjustment shall be required to be approved by the Town Council and recorded. Such plat showing said boundary line adjustment shall be titled with the same name as that of the original subdivision and shall include thereon that the replat is for the purpose of adjusting the lot lines between specific lots. (See Figure)

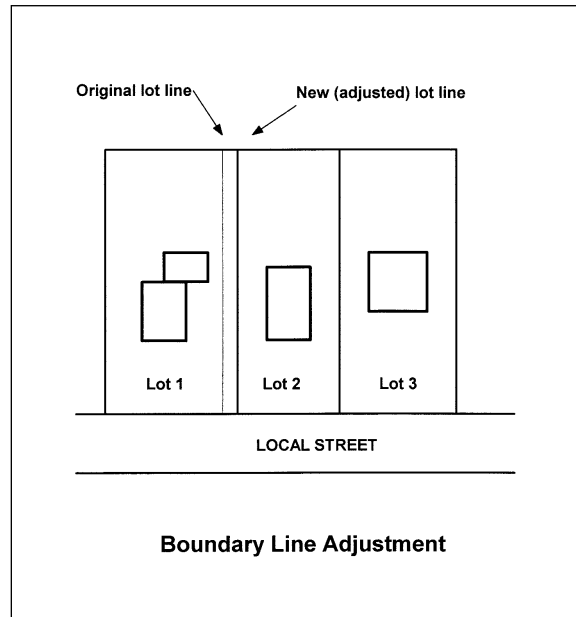

§1-9 DESIGN REQUIREMENTS FOR BLOCKS

§1-9.1 Block Length. Intersecting streets shall be provided at such intervals so as to provide adequate cross traffic. Blocks in residential subdivisions should not exceed 1,800 feet nor be less than 600 feet in length, except where topography or other conditions justify a departure from these standards. The Town Council may require pedestrian ways and/or easements through the block be located near the center in blocks longer than 800 feet.

§1-9.2 Block Width. The width of the block shall normally be sufficient to allow two tiers of lots of appropriate depth. Blocks intended for business or industrial use shall be of such width as to be considered most suitable for their respective use, including adequate space for off-street parking and deliveries. (See Figure).

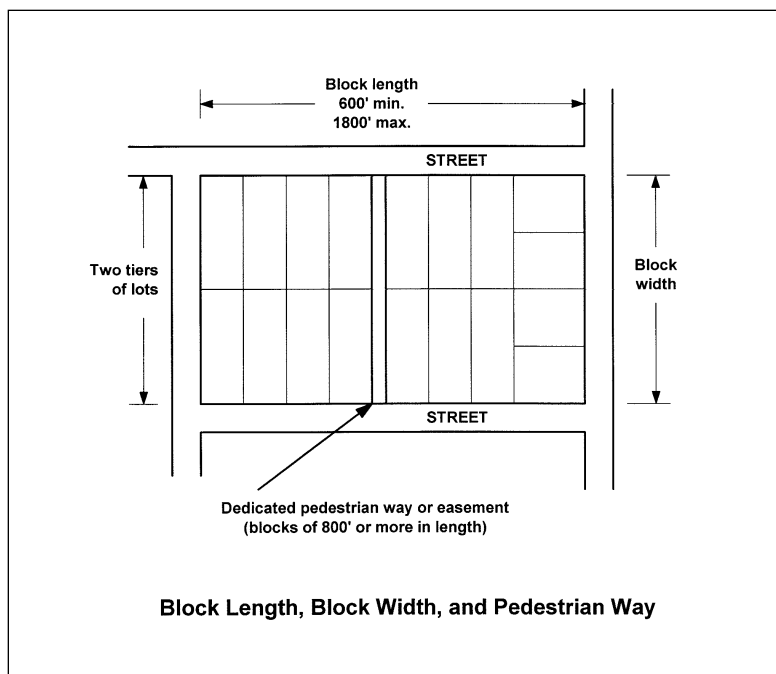

§1-10 DESIGN REQUIREMENTS FOR LOTS

§1-10.1 Natural Features and Assets. In the subdividing of land, due regard shall be shown for all natural features, such as tree growth, watercourses, historic sites or similar conditions which, if preserved, will add attractiveness to the proposed development and safety from hazards.

§1-10.2 Access and Minimum Lot Frontage. Each lot shall have access to a public street and a minimum of 60 feet of lot frontage on a public street; provided, however, that the local governing body may permit one or more lots to be accessed by private streets, as more fully specified in this ordinance; provided further, that in the case of a lot accessed by a circular cul-de-sac, the minimum lot frontage may be reduced to 30 feet.

§1-10.3 Adequate Buildable Area Required. Land subject to flooding, improper drainage or erosion, or that is unsuitable for residential or other use for topographical or other reasons, shall not be platted for residential use nor for any other use that will continue or increase the danger to health, safety, or of property destruction, unless the hazards can be and are corrected. Each lot shall contain an adequate building site not subject to flooding and outside the limits of any existing easements or building setback lines required by the local governing body. (See Figure).

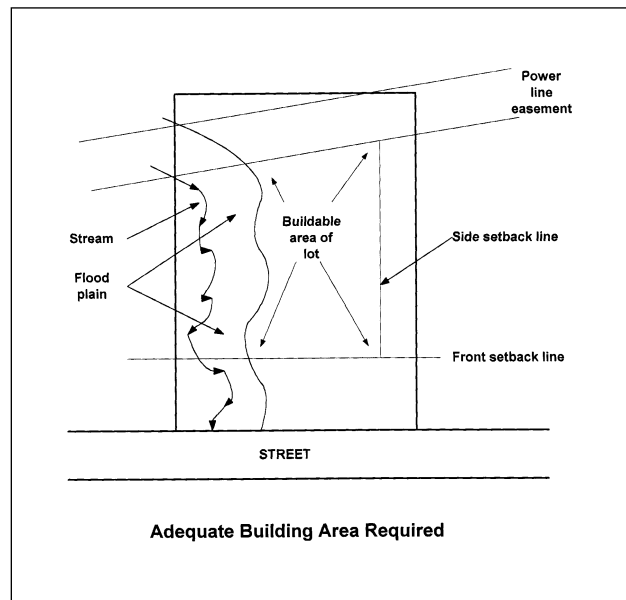

§1-10.4 Lot Remnants Not Permitted. All remnants of lots below any required minimum lot size that may be required, left over after subdividing of a larger tract, must be added to adjacent lots, rather than allowed to remain as unusable parcels. The Town Council may permit a lot remnant for a specific purpose such as a detention pond, provided that access and design is appropriate and the lot remnant is restricted to specific non-building use.

§1-10.5 Service Areas. Commercial and industrial lots shall be adequate to provide service areas and off-street parking suitable to the use intended.

§1-10.6 Lot Area. The minimum lot area shall not be less than that established by the land use intensity district in which the subdivision is located, or any other such ordinance provisions, if applicable.

§1-10.7 Lot Width. No portion of a lot shall be narrower than 60 feet, with the exception of cul-de-sac lots at the street frontage, nor shall any lot have a lot width less than that established by the land use intensity district in which the subdivision is located, if applicable.

§1-10.8 Lot Depth. Lots shall have a depth of not less than 100 feet, unless circumstances make these limitations impracticable.

§1-10.9 Flag lots.

- (a) Intent. Flag lots, as defined in this ordinance, are strongly discouraged. However, subdivisions designed with one or more flag lots may be approved where conditions of hardship make standard design or frontage impossible or impractical due to the configuration of the lot to be subdivided.
- (b) Denial if reasonable alternative exists. The Town Council shall have due cause to deny any plat that proposes any flag lot, when a reasonable alternative to such lot pattern is available.
- (c) Panhandle (flag pole) length restriction. If permitted, no flag lot shall be allowed to be platted that has a "panhandle" portion (i.e., portion that does not meet the required lot width) that is more than 400 feet in length.
- (d) Prohibition of abutting flag lots. If permitted, no flag lot shall abut another flag lot in any subdivision.

§1-10.10 Side Lot Lines. Insofar as practical, side lot lines shall be at right angles to straight street lines or radial to curved street lines.

§1-10.11 Corner Lots. Corner lots shall have adequate width to meet the front building setback requirements, if applicable, from all rights-of-way.

§1-10.12 Double Frontage Lots. Double frontage or "through" lots should be avoided except where essential to provide separation of residential development from arterials or overcome specific disadvantages of topography or orientation. Double frontage lots with frontage on a major arterial street shall have additional depth in order to allow space for screen planting along the lot line abutting a major arterial street.

§1-10.13 Mortgage Lot. This provision addresses situations where a bank requires the creation of small (e.g., 1-acre to 5-acre) tract of property from a larger existing parcel (usually farmland or timber land) in order to provide a mortgage or loan on a home or other principal building, rather than referring to the entire existing lot of record.

- (a) In cases where a person can show the Town Council in writing that an application for loan or mortgage involving real property has been filed with a bank or lending institution, and said bank or lending institution requires, for purposes of the loan or mortgage, a description of property that encompasses less land area than the lot of record, one or two mortgage lots (see definition) may be lawfully created from the parcel of record without constituting a subdivision. Minimum lot sizes established by any land use district or other ordinance requirement of the Town shall not be construed to prevent the creation of mortgage lots pursuant to this subsection, even if the resulting mortgage lot created is less than the minimum lot size required by said land use district or other ordinance requirement. The applicant shall be required in the case of a mortgage lot to file with the Town Council a copy of the survey plat creating the mortgage lot, and may be recorded in the records of the Coweta County Superior Court Clerk as a mortgage lot plat of record.
- (b) If created, a mortgage lot shall be no less than one acre and no larger than five acres in size. This provision shall not allow for the creation of a mortgage lot from any lot of record that is five acres or less in area.
- (c) No mortgage lot shall be created unless it has a minimum thirty-foot wide access easement from a road abutting the property frontage of the larger lot of record to the boundary of the mortgage lot.

§1-11 EASEMENTS

Where a watercourse, drainage way, channel or stream traverses a subdivision, there shall be provided a stormwater or drainage easement of adequate width. Easements shall be provided for all drainage facilities as approved by the Town Council. Where easements are needed for utility locations, the subdivider shall provide them to the appropriate utility provider. Where easements are needed for public water and/or sanitary sewer lines, they shall be provided as determined appropriate by the Town Council. All easements required pursuant to this section shall be shown on the preliminary plat, if required, and final plat.

§1-12 SURVEY MONUMENTS FOR ALL LOTS REQUIRED

For all subdivisions, a Georgia registered land surveyor shall install permanent survey monuments at all property corners and land lot lines, prior to final plat approval. Lot corners shall be marked with metal rods not less than 1/2" in diameter and 18" in length and driven so as to be stabilized in the ground. Permanent survey monuments shall also be installed in accordance with the most recent edition of Section 180-7-.05 Monument, of the *Rules of State Board of Registration for Professional Engineers & Land Surveyors* and the Georgia Plat Act (O.C.G.A. 15-6-67).

§1-13 PRELIMINARY PLAT

§1-13.1 Purpose. The purpose of this section is to ensure compliance with the basic design concepts and improvement requirements of subdivisions and land developments through the submittal of a preliminary plat of all major subdivisions for review and approval by the Town Council.

§1-13.2 When Required. All major subdivisions, as defined, shall require the submission of a preliminary plat for review and approval by the Town Council. Prior to the issuance of any permit for land disturbance or development, or the installation of any improvements, the Town Council must approve the preliminary plat, if required.

§1-13.3 Preliminary Plat Application and Specifications. Preliminary plat applications shall be made in accordance with requirements shown in Table 4-1, and preliminary plats shall meet the minimum plat specifications shown in Table 4-2.

§1-13.4 Procedures. Upon receipt of a completed preliminary plat application, the Town Clerk shall schedule the application for the next public meeting before the Planning Commission and forward all pertinent materials in the application to the Planning Commission for review. An application for preliminary plat approval must be submitted as least 14 days before the regular meeting date of the Planning Commission to be considered on that agenda. The Planning Commission shall have 50 days from the date the public meeting is held to forward a recommendation to the Town Council. After receipt of the Planning Commission's recommendation, the Town Council shall normally consider the application at its next regularly scheduled meeting. The Town Council shall have 50 days from the date of the public meeting to approve, conditionally approve, or deny the preliminary plat application. The basis of the Town Council's review of and action on a preliminary plat shall be whether the preliminary plat meets the purposes and requirements of this ordinance, and all other ordinances that relate to the proposed development.

§1-13.5 Public Notification. Due notice of the public meeting of the Town Council shall be published in the Town's legal organ or the newspaper of general circulation for the Town in which is carried the legal advertisements of the County by advertising the application and date, time, place, and purpose of the public meeting at least 15 days and not more than 45 days prior to such meeting.

§1-13.6 Disposition. Approval of a preliminary plat shall be valid for a period of one year, after which time a complete construction plans application must be submitted. If a completed application for construction plans is not submitted during that time, preliminary plat approval shall expire and be null and void.

§1-13.7 Amendments to Approved Preliminary Plats. The Town Council shall approve, conditionally approve, or deny all proposed amendments to a preliminary plat. Procedures for considering an amendment to a preliminary plat shall be the same as required for an initial application for preliminary plat approval (reference §1-13.4).

§1-14 CONSTRUCTION PLANS AND DEVELOPMENT PERMIT

§1-14.1 Application. Upon approval of a preliminary plat, or in the case of a minor subdivision, or in cases where a preliminary plat is not required by this article, the subdivider or land developer may apply for approval of construction plans and approval of a development permit. The subdivider or land developer may be required to meet with the Planning Commission and/or the Town Council to ensure that plans meet the intent and specific provisions of this ordinance and other applicable regulations. Applications for construction plan approval and development permit shall be made in accordance with requirements shown in Table 4-1 and Table 4-2. No application for construction plans shall be accepted for processing

nor development permit approved until a preliminary plat, if required, has been approved by the Town Council and the proposed construction plans are found to be in substantial conformity with said approval and any conditions of such approval. Procedures for considering applications for construction plan approval and development permit shall be the same as required for an application for preliminary plat approval (reference §1-13.4).

§1-14.2 Decision Criteria. The only basis upon which the Town Council may deny a construction plan or development permit is the failure of the application to meet the requirements of this ordinance or any other applicable local regulations or the failure of the construction plans and application to meet the requirements of preliminary plat approval specified by the Town Council.

§1-14.3 Certificate of Approval. All copies of the construction plans shall be noted by inscription on the plan noting such approval by the Town Council. Construction plan approval shall expire and be null and void after a period of one year, unless activity toward improvements on the land has been initiated, or unless the Town Council approves an extension of time.

§1-14.4 Engineered Drawings. Engineering drawings for public streets, including cross sections and centerline profiles, and public and private water, sewer, drainage, and utility systems, certified by a professional engineer registered in the State of Georgia, or if authorized under state law, a registered land surveyor, or professional landscape architect, shall be required to be submitted for review and approval, and such plans must meet the requirements of this ordinance and the specifications of the Town Council. Prior to approval and recording of a final plat, or prior to the approval of any certificate of occupancy, if required, a registered engineer for the subdivider/developer shall submit one copy of all finished, as-built plans of improvements, demonstrating that said improvements, as installed, meet the requirements of this ordinance and certifying that the plans accurately reflect actual construction and installation. The Town Clerk shall maintain all as-built street and utility plans for future use by the Town.

§1-14.5 Permits for Construction in Public Right-Of-Way. Permits from the Town Clerk shall be required for construction in any public right-of-way. Permits will not be issued until such time that plans have been submitted and approved by the Town Council.

§1-14.6 Improvements to Abutting Land. For subdivisions and land developments that abut and access an abutting public street, the subdivider or land developer shall install curb and gutter, sidewalk, other road improvements, and, if required, a deceleration lane, according to standards and specifications of this ordinance and the Town Council, along all abutting public streets. When a subdivision or land development uses an unpaved public right-of-way for access, the subdivider or land developer shall improve that right-of-way to a pavement width consistent with Town road design standards. Said improvements shall be from the subdivision or land development entrance to the paved road which the Town Council determines will be the primary direction of travel for residents of the subdivision or occupants of the land development.

§1-15 FINAL PLAT

§1-15.1 When Required. All major subdivisions, resubdivisions, minor subdivisions, and dedications shall require final plat approval. The final plat approval process is administrative except that in the case of a minor subdivision, or in cases where a preliminary plat is not required by this article, procedures for considering applications and for public notification shall be the same as required for an application for preliminary plat approval (reference §1-13.4 and §1-13.5). Applications shall be made in accordance with requirements shown in Table 4-1.

Table 4-1
Application Requirements

REQUIREMENT	MINOR SUBDIVISION	MAJOR SUBDIVISION		
		Preliminary Plat	Construction Plans	Final Plat
Pre-application review with Planning Commission	Recommended			
Application form completed		Required	Required	Required
Letter requesting approval with name, address, and phone of applicant	Required	Required		
Number of copies of plat	4	8	8	10
Filing fee per Resolution/schedule	Required	Required	Required	Required
Description of type of water supply and sewerage system and utilities to be provided	Required	Required	Required	Required
Soil test for each lot proposed for on-site septic tank and drainfield	Required	Required	Required	Required
Data on existing conditions		Required		
Hydrological or other engineering study			Required	
Subdivision entrance monument and landscaping elevation/plan			Required	
Warranty deed for the dedication of streets and other public places				Required
Written approval from electric utility company regarding installation of service points and street lights				Required
As-built drawings of public improvements	Required			Required
Subdivision improvement guarantee				Required
Certificate of title	Required			Required
Plat Certificates	Required			Required

§1-15.2 Criteria for Approval. The Town Council may grant final plat approval if the following conditions, as applicable, are met.

- (a) The Town Council has previously approved a preliminary plat of the proposed subdivision, if required (not required for minor subdivision).
- (b) Where new improvements are involved in the subdivision, construction plans have been approved by the Town Council, all improvements have been installed and inspected by the Land Use Officer, and subdivision improvement guarantees as required by this ordinance have been submitted.
- (c) The final plat meets all applicable requirements of this ordinance.
- (d) A complete final plat application has been submitted, including all supporting materials required by this ordinance for final plats.

The Town Council shall consider final plats and applications that meet the above-referenced conditions a ministerial action of approval. Denial of a final plat shall be permitted only upon specific findings that one or more of the above-referenced criteria have not been met.

Table 4-2
Plat and Plan Requirements

REQUIRED INFORMATION (Required to be on the plat or construction plans)	Preliminary Plat	Construction Plans	Final Plat
Scale (minimum)	1"=100 feet	1"=100 feet	1"=100 feet
Sheet size (maximum)	24" x 36"	24" x 36"	18" x 22"
North arrow and graphic engineering scale	Required	Required	Required
Reference to north point (magnetic, true north, or grid north)			Required
Proposed name of subdivision or project and phases, if any	Required	Required	Required
Vicinity map	Required	Required	Required
Total acreage of the property being subdivided	Required	Required	Required
Name, address, and telephone of owner of record	Required	Required	Required
Name, address and telephone of subdivider	Required	Required	Required
Name, address and telephone of preparer of plat	Required	Required	Required
Date of plat drawing and revision date(s), if any	Required	Required	Required
Exact boundaries of the tract to be subdivided by bearings and distances, tied to one or more benchmarks	Required	Required	Required
Names of owners of record of all abutting land	Required	Required	Required
Municipal, County and land lot lines inside the property or within 500 feet.	Required	Required	Required
Existing buildings and structures on or encroaching on the tract to be subdivided	Required	Required	Not Shown
Existing streets, utilities and easements on and adjacent to the tract	Required	Required	Required
Environmental conditions (streams, wetlands, watershed protection districts, flood hazard areas, river corridor boundaries, etc.)	Required	Required	Required
Block boundaries lettered and each lot numbered consecutively counterclockwise without repetition	Required		Required
Dimensions and acreage of all lots	Approximate	Approximate	Exact
REQUIRED INFORMATION	Preliminary	Construction	Final

(Required to be on the plat or construction plans)	Plat	Plans	Plat
Locations of streets, alleys, lots, open spaces, and any public use reservations and/or common areas	Required	Required	Required
Right-of-way widths and pavement widths for existing and proposed streets	Required	Required	Required
Locations, widths and purposes of easements		Required	Required
Street centerlines showing angles of deflection, angles of intersection, radii, and lengths of tangents and arcs, and degree of curvature and curve data		Required	Required
Acreage to be dedicated to the public	Recommended	Required	Required
Street names	Recommended	Required	Required
Street mailing address for each lot			Required
Topography	Per Town Council	Per Town Council	Not Shown
Minimum front building setback lines for all lots	Required	Required	Required
Location and description of all monuments	Recommended	Required	Required
Certificate of ownership and dedication			Required
Plat recording and signature block			Required
Plat Certificates: survey, owner, health department (see text)			Required
Signature block for Town Council approval	Required		Required
Land surveyor's stamp, certificate, signature, including field survey and closure statement		Required	Required
Statement of and reference to private covenants		Recommended	Required
Schedule of construction for all proposed projects with particular attention to development planned for the first year	Required	Required	

§1-15.3 Approval Certificate. Upon approval of the final plat, a certificate, stamped directly on the plat, shall state:

"Pursuant to the Land Subdivision Regulations of Town of Turin, Georgia, and all requirements of approval having been fulfilled, this final plat was given final approval by the Town Council and it is entitled to recordation in the Clerk's Office, Coweta County Superior Court.

"Mayor"

§1-15.4 Additional Plat Certificates. In addition to information required by Table 4-1 to be supplied on a final plat, each final plat shall contain the following certificates.

Surveyor's Certificate. A certificate by a surveyor directly on the final plat as follows:

"It is hereby certified that this plat is true and correct and was prepared from an actual survey of the property by me or persons under my supervision; that all monuments shown hereon actually exist or are marked as "future," and that their location, size, type and material are correctly shown; and that all engineering requirements of the Subdivisions and Land Development Ordinance of the Town of Turin, Georgia, have been fully complied with.

By: _____
Registered Georgia Land Surveyor No.: _____"

Owner's Certificate. A certificate by the owner directly on the final plat, signed in an appropriate manner as follows:

"The owner of the land shown on this plat and whose name is subscribed hereto, in person or through a duly authorized agent, certifies that this plat was made from an actual survey, and that all State, City and County taxes or other assessments now due on this land have been paid. Said owner donates and dedicates to the public for use forever the public street right-of-ways as shown on this plat.

Owner
Signed, sealed and delivered
in the presence of:

Witness

Notary Public"

Health Department Approval Certificate.

"This final plat has been approved by the Coweta County Health Department as being consistent with applicable state and local environmental health requirements.

Director, Coweta County Health Department"

§1-15.4 Distribution of Recorded Final Plat. The final plat is a source of essential information to tax officials, public safety officials, and utility officials, among others. The Town Clerk shall be responsible for ensuring that each agency listed in this subsection receives a copy of the final recorded plat with assigned addresses:

1. The County Tax Commissioner
2. The County Tax Assessor
3. The County Health Department
4. The County GIS Coordinator
5. The County 911 Coordinator
6. The County Public Works Department

At the discretion of the Land Use Officer, additional agencies or persons may be added to the above list.

§1-16 DEDICATIONS OF STREETS AND PUBLIC LANDS

Upon completion of public improvement construction, the subdivider or land developer shall notify the Land Use Officer and request an inspection. The Land Use Officer shall inspect, or shall cause an inspection of, all public improvements and shall notify the subdivider or land developer by mail of nonacceptance or preliminary acceptance. If the public improvements are not acceptable, the reason for non-acceptance shall be stated and corrective measures shall be outlined in a letter of notification. Upon notification, the subdivider or land developer shall correct all deficiencies identified in the non-acceptance letter within the time limit established by the Land Use Officer. Once deficiencies are corrected, the subdivider or land developer shall again request inspection in writing. Acceptance of public improvements required by this ordinance to be approved by the local governing body shall be forwarded to the Town Council by the Land Use Officer following approval.

Subdivision streets and right-of-ways and other lands to be dedicated to the public shall be accepted and dedicated by the Town only upon the delivery to the Town Council of the general warranty deed conveying fee simple title of such right-of-ways and lands. The warranty deed shall be accompanied by an attorney's certificate of title and a tax transfer form addressed to the Town Council certifying that the grantor in such deed is vested with marketable fee simple title to the property conveyed thereby, free and clear of all liens and encumbrances, and further that the individual executing such deed has full authority to do so. Acceptance of such dedication shall be accomplished by Resolution of the Town Council.

§1-17 SUBDIVISION IMPROVEMENT GUARANTEES

In order to protect the Town and prospective purchasers of and residents in a subdivision, the subdivider/developer shall provide to the Town financial security to guarantee the installation of public improvements. The subdivider's or developer's financial guarantee may be any of the following:

- (a) An escrow of funds with the Town;
- (b) An escrow with a bank or savings and loan association upon which the Town can draw;
- (c) An irrevocable letter of commitment or credit upon which the Town can draw;
- (d) A performance bond for the benefit of the Town upon which the Town can collect, or a certificate of deposit with assignment letter; and
- (e) Any other form of guarantee approved by the Town Council that will satisfy the objectives of this section. The guarantee shall be in an amount to secure the full costs, as determined by the Town, of constructing or installing the improvements and utilities required.

§1-18 LIMITATIONS ON MINOR SUBDIVISIONS

§1-18.1 Purpose. Minor subdivisions provide certain advantages, such as a shorter application process and less public scrutiny, that tend to favor their use over the filing of major subdivision applications. Given these advantages, the prospect exists that subdividers may seek to divide a parcel via consecutive and/or contiguous minor subdivisions instead of filing for a major subdivision. It is the intent of the Town Council to prohibit the practice of "chain" subdivisions where the same land owner subdivides land and then files minor subdivision applications on common contiguous parcels, which collectively total more than four lots. It is also the intent of the Town Council to prohibit minor subdivisions adjacent to each other within a three-year time period, in cases where part of an original tract of land is now owned by another person or entity and was transferred or sold to another owner with the apparent intent to circumvent the major subdivision process.

§1-18.2 Common Contiguous Parcels Shown on Minor Subdivision Plats. Contiguous common parcels, as defined by this ordinance, shall be referenced on all applications for minor subdivisions, and contiguous common parcels shall be considered part of any application for minor subdivision, for purposes of determining whether or not the division of land proposed is a major subdivision or a minor subdivision. Common contiguous parcels shall not be counted as lots in the case of a minor subdivision.

§1-18.3 Limitations. Land within a minor subdivision, including all contiguous parcels owned by the subdivider, shall not be further divided for a period of three years unless a preliminary plat application is filed and approved as a major subdivision pursuant to the requirements of this ordinance. If property proposed to be subdivided was part of an original tract, and if the property proposed to be subdivided abuts land that has been divided as a minor subdivision in the last three years, then minor subdivision of said property shall be prohibited. This provision shall not be construed to prohibit the approval of two contiguous minor subdivisions under separate ownership; however, this provision is intended to be construed so that one property owner does not develop a minor subdivision on part of an original tract and transfer or sell another part of the original tract for the purposes of minor subdivision within a three year period. It is the intent that land abutting a minor subdivision that was owned by the subdivider of the abutting minor subdivision shall not be subdivided as a minor subdivision for a period of three years, regardless of ownership.

§1-18.4 Requirements. Lots created or subdivided as a minor subdivision shall comply with the following:

- (a) Each lot complies with all requirements of the Zoning Ordinance and is limited to single-family detached residential use.
- (b) Each proposed lot fronts on an existing public street having a right-of-way not less than City minimum for the street category given to the existing public street.
- (c) Each proposed lot complies with the requirements of the Health Department.
- (d) Each lot thus created may not be resubdivided pursuant to the provisions of this subparagraph. Such resubdivisions shall be accomplished only through the subdivision procedures contained in these Regulations.

§1-19 STANDARDS FOR CONFIGURING NEW STREETS

§1-19.1 Street Alignment, Intersections and Jogs. Streets shall be aligned to join with planned or existing streets. Under normal conditions, streets shall be laid out so as to intersect as nearly as possible at right angles (90 degrees), but in no case shall such a street intersection be less than 75 degrees. Where street offsets or jogs cannot be avoided, offset "T"

intersections shall be separated by a minimum centerline offset of 150 feet in urban areas and 300 feet in rural areas. (See Figure).

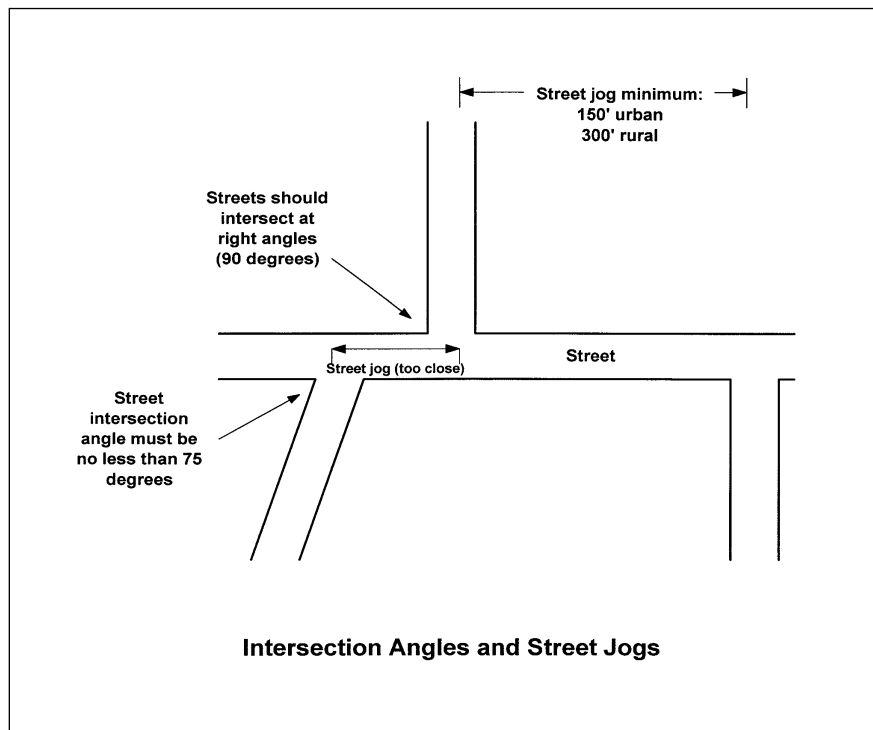

§1-19.2 Continuation of Existing Streets and Connections. Existing streets, and their rights-of-way, shall be continued at the same or greater width, but in no case less than the required width. The Town Council may require that a major subdivision provide one or more future connections to adjoining subdivisions or unsubdivided tracts.

§1-19.3 Street Plans for Future Phases of the Tract. Where the plat or site plan proposed to be subdivided or developed includes only part of the tract owned or intended for subdivision or development by the subdivider or land developer, a tentative plan of a future street system for the portion not slated for immediate subdivision consideration may be required by the Land Use Officer and if required shall be prepared and submitted by the subdivider or land developer.

§1-19.4 Dead-End Streets and Cul-De-Sacs. Streets that dead-end shall terminate in a cul-de-sac. The maximum length of such streets shall be 1,200 feet. Streets that are planned to continue at some future date shall provide a temporary cul-de-sac as required by the Land Use Officer.

§1-19.5 Marginal Access Streets. Whenever a major subdivision is proposed abutting the right-of-way of a U.S. or State highway, a marginal access street approximately parallel and adjacent to such right-of-way may be required by the Town Council at a distance suitable for the appropriate use of land between such marginal access street and highway right-of-way. The Town Council may also require a 20-foot no-access easement and planting strip along the major arterial street to ensure that lots fronting on said street do not have access thereto. (See Figure).

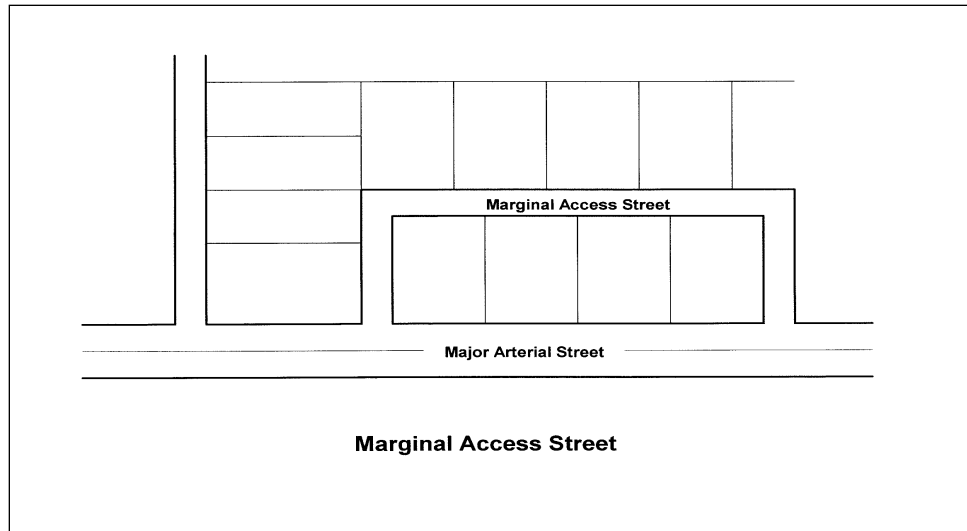

§1-19.6 Alleys and Service Access. Alleys may be provided. If they are provided, they must be paved. Dead-end alleys shall be avoided where possible; but if unavoidable, they shall be provided with adequate turn-around facilities. Service access shall be provided to commercial and industrial developments for off-street loading, unloading, and parking consistent with and adequate for the uses proposed.

§1-20 REQUIREMENTS FOR STREETS

§1-20.1 Bridges. Bridges on public rights-of-way shall meet current American Association of State Highway and Transportation Officials standards.

§1-20.2 Grading and Stabilization of Street Rights-Of-Ways. When a new public street is proposed, all trees, brush, stumps, rocks, or other debris shall be cleared from the street right-of-way, except in cases where trees are required to be preserved by the Land Use Officer. All streets shall be graded to lines, grades and cross sections approved on plans. All unsurfaced, disturbed portions of street rights-of-way shall be stabilized by seeding, fertilizing, and mulching or by another equally effective method.

§1-20.3 Radius at Street Intersections. The right-of-way radius at street intersections shall be a minimum of 15 feet, with larger radii for streets serving nonresidential development, as approved by the Land Use Officer. The minimum pavement (curb) radius at street intersections shall be 25 feet.

§1-20.4 Street Grades. No street grade shall be less than one percent. No street grade for an arterial or collector street shall exceed eight percent. No other local street grade shall exceed 12 percent, unless the Land Use Officer finds that due to topographic conditions, a steeper grade is necessary, in which case the street grade shall not exceed 15 percent. Grades between 12 percent and 15 percent shall not exceed a length of 150 feet.

§1-20.5 Minimum Street Right-Of-Way and Pavement Widths. Street right-of-way and pavement widths shall at minimum meet the following:

STREET TYPE	MINIMUM RIGHT-OF-WAY WIDTH (FEET)	MINIMUM PAVEMENT WIDTH (FEET)
Major arterial street	Per thoroughfare plan	Per thoroughfare plan
Collector street	60	36
Local street with curb and gutter	50	24 (back of curb to back of curb)
Local street without curb and gutter	60	24
Cul-de-sac turn around radius	50	40 (back of curb)
Alley	20	16

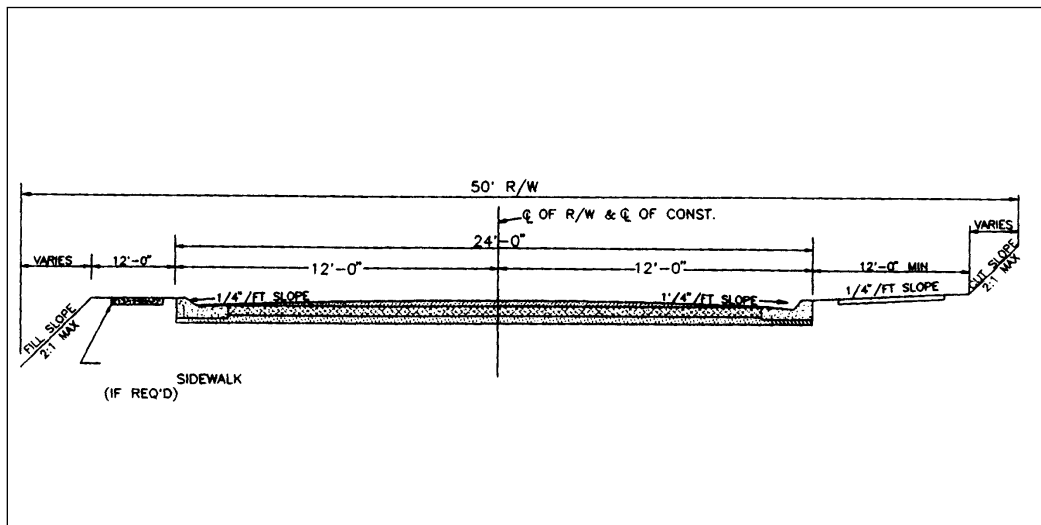

Residential Street with Curb and Gutter
(Cross Section Detail)

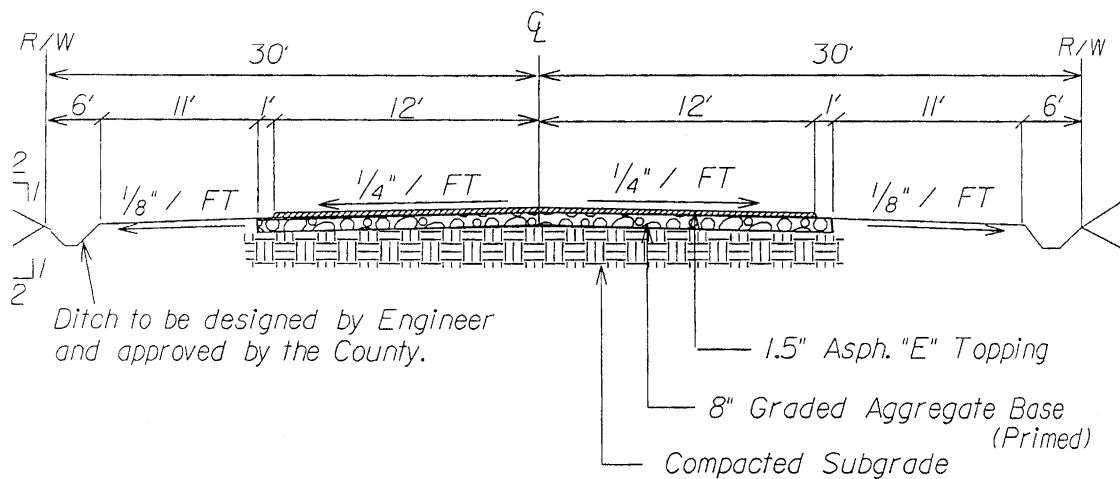

**Local Street
(Rural Cross-Section)**

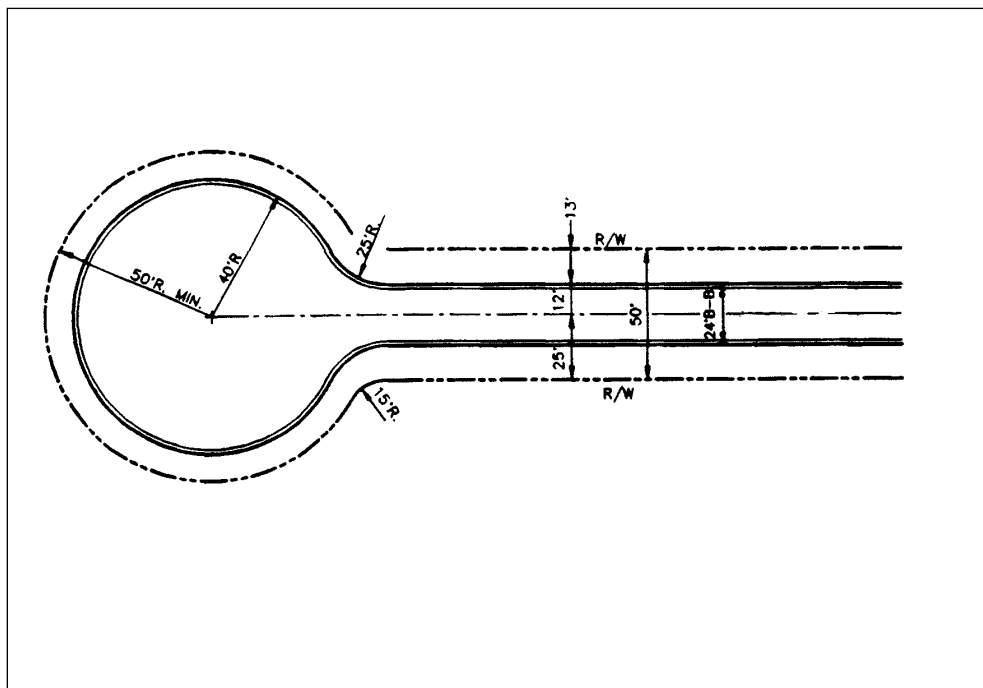

Cul-de Sac Detail

§1-20.6 Street Horizontal Alignment and Reverse Curves. Street horizontal alignments and reverse curves shall at minimum meet the following:

STREET TYPE	MINIMUM HORIZONTAL RADII OF CENTER LINE CURVATURE (FEET)	MINIMUM TANGENTS BETWEEN REVERSE CURVES (FEET)
Major arterial street	1,250	250
Collector street	500	100
Local street with curb and gutter	100	50
Local street without curb and gutter	100	50
Dead-end street	100	50

§1-21 CURB CUTS AND ACCESS SPECIFICATIONS

§1-21.1 Entrance Improvement Specifications. Roadway entrances and improvements, including necessary acceleration and/or deceleration lane(s) and right/left turn lanes, shall be designed, installed, and maintained as approved by the State Department of Transportation, as applicable, or the Land Use Officer, in accordance with applicable State or County specifications. All entrances or exits of any street or driveway, public or private, from or to any state highway shall be approved by the State Department of Transportation and the Land Use Officer prior to the construction of such entrances or exits and prior to the issuance of any land use permit or building permit for any improvement to be served by such entrances or exits. All

entrances or exits of any street or driveway, public or private, from or to any County street shall be approved by the Land Use Officer prior to the construction of such entrances or exits and prior to the issuance of any land use permit or building permit for any improvement to be served by such entrances or exits.

§1-21.2 Curb Cut Specifications. No curb cut or access driveway shall be permitted to be located closer than 100 feet to the nearest existing or proposed right-of-way of an intersecting roadway. Curb cuts or access driveways shall be no narrower than 24 feet from back of curb to back of curb. Strict adherence to these requirements may not be practical in all instances as determined by the Land Use Officer. The Land Use Officer may limit the maximum width of a curb cut and/or the number of curb cuts to a parcel as necessary when it is deemed to be of benefit to the safety and welfare of the public.

The following factors may be considered during the review and approval of a specific location of an entrance: the location of existing or planned median breaks; separation requirements between the entrance and major intersections; separation requirements between other entrances; the need to provide shared access with other sites; the need to align with previously approved or constructed access points on the opposite side of the street; and the minimum number of entrances needed to move traffic onto and off the site safely and efficiently.

§1-21.3 Access Along and Near Divided Highways. Where a divided highway exists or is planned, the following access standards shall be met:

Minimum Access Separation Requirements	Distance (Feet)
Curb cut of driveway from street intersection with divided highway	600
Parallel frontage road from right-of-way of divided highway	450
Curb cut or driveway on a local road from right-of-way of divided highway	200
Curb cut or driveway on a local road from state highway	200
Curb cut or driveway on parallel frontage road from local road	150

§1-21.4 Interparcel Connections. New development that contains or is intended to contain more than one building or use on site shall provide connections so that automobile trips between and among such buildings or uses can be accomplished without using the highway or major street. Where possible and practical, new developments and substantial improvements to existing developments shall provide for pedestrian and automobile access connections between adjacent properties under different ownership when the uses of the properties are of such compatibility that patrons may frequent both buildings or uses in the same vehicle trip.

§1-21.5 Street Access. No building or structure may be constructed or placed on a lot unless such lot abuts a street, as the term "street" is defined herein

§1-22 STREET LIGHTING

Street lights may be provided in accordance with Town specifications by the developers of a subdivision prior to the approval of a final plat. Fixtures and standards/poles installed or used shall be approved by the Town and by the utility company that will be responsible for the maintenance of the facilities. The fixtures shall be mounted no more than thirty (30) feet above the ground and shall have appropriate arm length or power to place light over the street. Post top luminaries may be permitted when approved by the Land Use Officer. Fixtures shall be located no more than five hundred (500) feet apart, unless approved by the Land Use Officer,

and, when provided, at least one light shall be located at each public or private street intersection within the subdivision or land development.

The developer shall pay all costs for poles, fixtures and any other related items or materials necessary for the installation of street lights, as well as arrange an agreement with the utility company for complete maintenance of all installations. The Town may assume the responsibility and make the monthly payments to the power company for electrical energy for each street light only after these requirements have been accomplished and improvements accepted by the local governing body. Maintenance and operation costs of street lights will be assumed by the Town no earlier than two years after lights have been installed.

§1-23 STREET SIGNS

Signs for street names, directions of travel, traffic control, and hazards shall be provided as directed by the Land Use Officer. Street signs on exterior/boundary streets shall be installed by the Town with the developer paying a proportionate share determined by the Town. Street signs for interior streets of a subdivision or land development shall be installed at the subdivider or developer's expense by the subdivider or developer, subject to the approval of the Land Use Officer.

Unless otherwise provided in standards and specifications adopted by the Town, street signs shall meet the following specifications. Signs shall be constructed of aluminum sheets with reflective backgrounds. Information on the street name signs shall be readable from both sides of the sign. Signs shall be installed on a steel post. The vertical distance from the road elevation to the bottom of the sign face shall be seven feet with a minimum burial depth of three feet.

§1-24 CURBS AND GUTTERS

Curbs and gutters shall be installed if required by the Land Use Officer in accordance with standards and specifications of the Town. Subdivisions consisting totally of lots intended for single-family residential use containing a minimum of two acres shall not require curbs and gutters, provided, however, that curbs are required for all roads when sidewalks are required by this ordinance. All commercial and industrial subdivisions and land developments must have curbs and gutters, regardless of the size of the lots. When property fronting on an existing street is subdivided or developed, and the subdivision or land development uses said existing street for access, then curb and gutter shall be required along said street along the entire property frontage of said street.

Curbs shall be concrete which shall be class A 3000 psi strength at 28 days. The typical curb minimum section shall be six inches by 24 inches by 12 inches (see Figure).

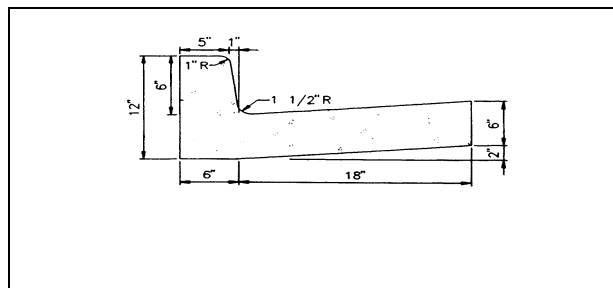

Vertical Curb Detail

All streets and roads not required to include curbs and gutters shall be graded, paved, and drained to meet all construction and drainage standards for ditches, slopes, and grassing according to specifications established by the Town.

§1-25 SIDEWALKS

§1-25.1 When Required. Sidewalks shall be provided in accordance with the Comprehensive Plan, unless the Land Use Officer determines that no public need exists for sidewalks in a certain location. Sidewalks shall be required when land developments and subdivisions are located within one-mile of a public school. Sidewalks are required to be installed along one side of the street internal to a major subdivision, except in cases where the median lot size of the major subdivision is two acres or more.

§1-25.2 Location. Sidewalks shall be included within the dedicated nonpavement right-of-way of roads and shall parallel the street pavement as much as possible; provided, however, the Land Use Officer may permit sidewalks to be designed and constructed so that they meander around permanent obstructions or deviate from a linear pattern for design purposes.

§1-25.3 Specifications. Sidewalks shall be a minimum of four feet wide. A median strip of grassed or landscaped areas at least two feet wide shall separate all sidewalks from adjacent curbs in residential areas.

§1-26 PRIVATE STREETS

§1-26.1 Private Streets Permitted. Private streets may, upon application, be permitted by the Town Council within major subdivisions, subject to the requirements of this section. Applications for approval of private streets shall be considered by the Town Council at the time of preliminary plat approval by the Town Council. Following a recommendation by the Planning Commission to authorize private streets in a major subdivision, the Town Council shall consider the application and may impose conditions on the approval of private streets to ensure various public purposes and to mitigate potential problems with private streets. No final plat involving a private street shall be approved unless said final plat conforms to the requirements of this section.

§1-26.2 Construction Plans Required. It shall be unlawful for any person, firm, or corporation to construct a new private street or alter an existing private street or to cause the same to be done without first obtaining approval of construction plans from the Town Council and a development permit issued in accordance with the requirements of this ordinance.

§1-26.3 Standards. All private streets shall be constructed to all standards for public streets as required by this ordinance for public streets, applicable construction specifications of the Town, and as approved by the Town Council.

§1-26.4 Street Names And Signs. Private streets shall be named, subject to the approval of the Land Use Officer. The subdivider of land involving a private street shall install street signs with content containing the street name and the designation "private," as approved by the Land Use Officer. The sign signifying the private street may be required by the Town to be a different color than that of street signs provided for public streets, in order to distinguish maintenance responsibilities in the field.

§1-26.5 Easements. Easements for private streets shall be designated on final plats as general-purpose public access and utility easements, along with the name of said private street. Said easement shall at minimum be of the same width as that required for the right-of-way of a public street by the major thoroughfare plan and the Town for the type of public street (local, collector, etc.) most closely resembling the proposed private street. Easements for private

streets shall not be included in any calculation of minimum lot size or density limitations established by local land use regulations. In the cases of private streets, the general-purpose public access and utility easement for the private street shall either;

- (a) Be shown in a manner on the final plat such that each lot fronting the private street extends to the centerline of the private street. No lot shall be permitted to be divided by the general purpose public access and utility easement required and established for a private street; or
- (b) Shall be drawn as its own discrete parcel to be dedicated to a private homeowners association (i.e., not shown to be a part of any lot).

§1-26.6 Maintenance. The Town shall not maintain, repair, resurface, rebuild, or otherwise improve streets, signs, drainage improvements or any other appurtenances within general purpose public access and utility easements established for private streets. A private maintenance covenant recorded with the Clerk of the Superior Court of Coweta County shall be required for any private street and other improvements within general-purpose public access and utility easements established for private streets. The covenant shall set out the distribution of expenses, remedies for non-compliance with the terms of the agreement, rights to the use of easements, and other pertinent considerations. The Covenant shall specifically include the following terms.

- (a) The Covenant shall establish minimum annual assessments in an amount adequate to defray costs of ordinary maintenance and procedures for approval of additional needed assessments. The Covenant shall also specify that the funds from such assessments will be held by a homeowners or property owners association in cases of a subdivision of seven or more lots fronting on a private street.
- (b) The Covenant shall include a periodic maintenance schedule.
- (c) The Covenant for maintenance shall be enforceable by any property owner served by the private street.
- (d) The Covenant shall establish a formula for assessing maintenance and repair costs equitably to property owners served by the private street.
- (e) The Covenant shall run with the land.
- (f) The Town Council may, at its discretion, as a condition of approving private streets, require a performance bond and/or maintenance bond be submitted by the subdivider and held by a homeowners or property owners association, or the Board may require that the subdivider pay an amount of money as recommended by the Land Use Officer into an escrow account or other suitable account for the maintenance and repair of private streets and stormwater management improvements, to be drawn from by the homeowners or property owners association as maintenance and repair needs may arise.

§1-26.7 Specifications For Final Plats Involving Private Streets. The Town Council shall not approve for recording any final plat involving a private street unless and until it shall contain the following on the face of the plat:

- (a) Deed book and page reference to the recorded covenant required by this section;
- (b) "WARNING, the Town of Turin has no responsibility to build, improve, maintain, or otherwise service the private streets, drainage improvements, and other appurtenances contained within the general public purpose access and utility easement or easements for private streets shown on this plat.";

- (c) "Grant of Easement. The general purpose public access and utility easement(s) shown on this plat for private street(s) is hereby granted and said grant of rights shall be liberally construed to provide all necessary authority to the Town, and to public or private utility companies serving the subdivision, for the installation and maintenance of utilities, including, but not limited to, electric lines, gas lines, telephone lines, water lines, sewer lines, cable television lines, and fiber optic cables, together with the right to trim interfering trees and brush, together with a perpetual right of ingress and egress for installation, maintenance, and replacement of such lines.

Signature of Property Owner"; and,

- (d) (The following certificate of dedication shall be required, unless the Town Council waives the dedication requirement.)

"Certificate of Dedication. All water and sewer lines installed within the general purpose public access and utility easement(s) shown on this plat for private street(s) are hereby dedicated to the Town of Turin.

Signature of Property Owner."

§1-26.8 Requirement for Purchaser's Acknowledgement of Private Responsibilities.
Prior to the sale or as a condition of the closing of a real estate transaction involving any lot served by a private street in the Town, the subdivider or seller of said lot shall execute a notarized purchaser's acknowledgement of private street construction and drainage maintenance responsibilities as set forth below. A copy of the purchaser's acknowledgement shall be retained by the purchaser and shall be required to be submitted as a condition of a building permit for a principal building on said lot:

"Purchaser's Acknowledgement of Private Street and Drainage Maintenance Responsibility

(I) / (We) have read the Declaration of Covenant which pertains to the lot that is the subject of this real estate transaction _____ (insert address or attach legal description). (I) / (We) understand that the Declaration of Covenant applies to the lot that (I am) / (we are) purchasing and requires (me) / (us) to provide a specified percentage or amount of the financing for the construction and maintenance of any private street and drainage facilities serving the lot which (I am) / (we are) purchasing, and that owners of other lots in this plat may sue for and recover those costs which this covenant requires (me) / (us) to pay, plus their damages resulting from (my) / (our) refusal to contribute, plus reasonable attorneys fees. (I) / (We) further understand that the Town of Turin has no obligation to assist with the maintenance and improvement of the private street, drainage facilities, and other appurtenances within the general purpose public access and utility easement for the private road serving the lot in question. (I) / (We) understand that a copy of this purchaser's acknowledgement shall be

required as a condition of the issuance of a building permit for a principal building on the lot (I am) / (we are) purchasing.

Purchaser

Purchaser”

§1-27 DRAINAGE AND STORMWATER MANAGEMENT

§1-27.1 General Requirements. An adequate drainage system, separate and independent of any sanitary sewer system and including any necessary ditches, pipes, culverts, intersectional drains, drop inlets, bridges, etc., shall be provided for the proper drainage of all surface water for all subdivisions and land developments. Sizing and location of all drainage structures shall be the responsibility of a registered professional engineer or land surveyor. The Town may require the use of on-site control methods such as retention or detention to mitigate the stormwater and drainage impacts of the proposed subdivisions and land developments. The Town Council shall not approve any preliminary plat of subdivision that does not make adequate provision for storm and flood water runoff channels or basins. No building permit shall be issued for any building within a subdivision or development permit issued for the development of land, if there is not present throughout the subdivision or to the land development an adequate system of drainage and stormwater management.

§1-27.2 Method of Design and Capacity. Storm sewers, where required, shall be designed by the Rational Method, or other methods as approved by the Town, and a copy of design computations shall be submitted along with required plans. Drainage improvements shall accommodate potential runoff from the entire upstream drainage area within the site and shall be designed to prevent increases in downstream flooding. Capacity for a 10-year storm or rain shall be provided for all street drainage structures such as catch basin, inlets cross drains, etc. Capacity for a 100-year frequency storm event shall be provided for all main drainage structures such as retention basins, principal storm sewers, and all types of flood protection works.

§1-27.3 Location. Drainage facilities shall be located in the road right-of-way where feasible, and shall be constructed in accordance with standards and specifications of the Town. Catch basins shall be located at low points of streets. Where topography or other conditions are such as to make impractical the inclusion of drainage facilities within road rights-of-way, perpetual, unobstructed easements at least fifteen (15) feet in width for drainage facilities shall be provided across property outside the road right-of-way and with satisfactory access to the road.

§1-27.4 Discharge. Drainage shall be designed so as to avoid concentration of storm drainage water from each lot or land development site to adjacent lots, land development sites, or vacant properties. Storm water shall not be discharged directly to perennial streams. It shall be directed toward natural drainages. If water must be discharged to a stream, the water quality flowing into the stream must meet or exceed the water quality in the receiving waters. The water quantity flowing into the stream must be evaluated to ensure the stream channel can accommodate the increased flows and not disrupt or degrade the ecology of the water body.

§1-27.5 Grading and Site Drainage. Lots or land development sites shall be laid out so as to provide positive drainage away from all buildings, and drainage for individual lots or land development sites shall be coordinated with the general storm drainage pattern for the area. Buildings and parking lots shall be appropriately drained so as to prevent damage to abutting properties or public streets. All disturbed or graded ground areas of a building site not used for buildings or open storage areas shall be appropriately stabilized and grassed or covered with plants or landscaping materials.

§1-27.6 Cross-Drainpipes. Where a watercourse separates the buildable area of a lot from the street by which it has access, provisions shall be made for installation of a culvert or other structure, the design of which shall be approved by the Town. Cross-drains shall be provided to accommodate all natural waterflow, and shall be of sufficient length to permit full-width roadways and the required slopes. Cross drainpipes shall have head walls of an approved type on inlet and outlet ends of the pipe. Pipe installed within the right-of-way shall be reinforced concrete pipe. All storm drainpipes shall be minimum 18 inches in diameter. Storm sewer slopes shall be equal to or greater than one percent.

§1-27.7 Drop Inlets. Drop inlets shall be generally three-foot by three-foot boxes with two-foot by three-foot grates unless otherwise specified by the Town.

§27.8 Easements. Where an irrigation ditch or channel, natural creek, stream or other drainage way crosses a subdivision or land development, the subdivider or developer shall provide an easement sufficient for drainage and maintenance. Easements shall be provided for all drainage facilities as approved by the Town. When a subdivision or land development is traversed by a watercourse, drainage way, channel, or intermittent stream, a stormwater or drainage easement of at least twenty (20) feet shall be provided.

§1-28 WATER

§1-28.1 Generally. All habitable buildings and buildable lots shall be connected to a water system capable of providing water for health and emergency purposes, including adequate fire protection. No permit shall be issued for any building within a subdivision or for the development of land, if there is not present throughout the subdivision or to the land development an adequate water supply.

§1-28.2 Water Main Requirements. When a public water main is accessible, the developer shall install adequate water facilities, including fire hydrants, according to specifications of the Town. All water mains shall be at least eight inches in diameter except that pipe of lesser size may be used if properly looped and adequate water pressure is maintained in accordance with standards established by the Southeastern Fire Underwriters Association. Pipe of less than four inches shall not be used except in unusual cases. Water lines shall be installed at least 30 inches below grade. Water mains within subdivisions and land developments must be provided with connections to each lot in the subdivision and each land development, except as otherwise specifically provided.

§1-28.3 Wells. If a County and/or municipal water supply is not available to the subdivision or land development at the time of constructing improvements for a subdivision or land development, then the subdivider or developer shall provide an adequate alternative water source and an adequate water storage facility. In subdivisions or land developments with a residential density of one unit per acre or less and when a public water system is not available as determined by the Town, individual wells may be used in a manner so that an adequate supply of potable water will be available to every lot in the subdivision or to the land development. When individual wells are proposed to be used for water supply, water samples shall be submitted to the County Health Department for its approval, and individual wells shall be approved by the County Health Department. Approvals shall be submitted to the Land Use Officer prior to final subdivision plat approval.

§1-28.4 Community Water System. If a County and/or municipal water supply is not available to the subdivision or land development at the time of constructing improvements for a subdivision or land development, then the subdivider or developer shall provide an adequate alternative water source and an adequate water storage facility. Any community water system, if permitted, shall provide a minimum flow of 400 gallons per day per each lot platted, whether or not each lot is to be immediately developed; shall be sanitary; and shall have a minimum pressure of 30 pounds per square inch at each lot in the subdivision or each land development to be served. For all common non-public water supply systems, acceptable management, maintenance, and distribution policies and procedures shall be established. These policies and procedures shall be required to guarantee the provision of adequate supplies to each perspective lot owner on a continuing, ongoing basis, and to provide acceptable means for repairs and unforeseen events. The community water system plan shall be approved by the Coweta County Health Department and a letter of approval from the Georgia Department of Natural Resources shall accompany the final plat or land development application.

§1-28.5 Fire Hydrants. Fire hydrants shall be required for all nonresidential land developments and all subdivisions except those permitted to be served by individual on-site wells. Fire hydrants with appropriate water pressure at appropriate intervals throughout the subdivision or land development shall be provided by the subdivider or land developer as required by the County Fire Department. Fire hydrants shall be located no more than 1,000 feet apart and within 500 feet of any principal dwelling. Hydrants, fittings, valves and fire department connections shall be approved by the Fire Department. Fire department connections shall be not less than 18 inches or more than 36 inches above the level of the adjoining ground or paving. The thread of such connections shall be uniform with that used by the Fire Department. To eliminate future street openings, all underground utilities for fire hydrants, together with the fire hydrants themselves, and all other supply improvements shall be installed before any final paving of a street within the right-of-way shared by such underground utilities.

§1-29 SEWER

§1-29.1 Generally. All habitable buildings and buildable lots shall be served by an approved means of wastewater collection and treatment. Each subdivision and land development shall be served by adequate sewage disposal facilities. No permit shall be issued for any building within a subdivision or for the development of land, if there is not present throughout the subdivision or to the land development an adequate system of wastewater collection and treatment.

§1-29.2 Connection to Public Sewerage System. When a public sanitary sewerage system is reasonably accessible, as determined by the Town, the subdivider or land developer shall connect with same and provide sewers accessible to each lot in the subdivision or to each land development. If a public sanitary sewer is reasonably accessible, it shall be unlawful for any person to maintain upon any such property an individual sewage disposal system. When a public sanitary sewerage system is not immediately accessible but is anticipated by the Town to be available within a period of three years, the applicant shall install sanitary sewer lines, laterals, and mains from the street curb to a point in the subdivision or land development boundary so that a future connection with the public sewer main can be made. The Town Council may condition the approval of a subdivision or land development on the agreement to connect to the public sewerage system upon its availability. Sanitary sewers shall be located within street or alley rights-of-way unless topography dictates otherwise. No public sewer shall be less than eight inches in diameter. Manholes shall be installed in sanitary sewers with a maximum distance between two manholes of 400 feet, unless otherwise specified by standards of the Town. Sanitary sewer slopes shall be equal to or greater than 0.7 percent for eight inch

lines. All sewer lines shall be designed with slopes to obtain a minimum velocity of two feet per second. Minimum 20-foot wide easements shall be provided for all sanitary sewer lines.

§1-29.3 Alternative Provision. If sanitary sewer is not available at the time of the development of the subdivision or land development, and if sanitary sewer is not anticipated to be available within a period of three years to serve the subdivision or land development in question, then on-site septic tanks, an oxidation pond, or another approved method of treatment of sanitary sewerage shall be installed by and at the expense of the subdivider or land developer in conformity with the requirements of the County Health Department and according to specifications adopted by the Town.

§1-29.4 Septic Tanks. Where individual onsite wastewater disposal systems are allowed and proposed, individual lot sizes and shapes must exhibit appropriate regard for the peculiar health, drainage, and maintenance characteristics on the site. Additionally, detailed soil tests may be required in order to verify the ability of the lots to safely contain and dispose of septic system effluent. All septic tanks and onsite wastewater disposal systems are subject to the approval of the Coweta County Health Department.

§1-30 UTILITIES

All utility facilities, including but not limited to gas, electric power, telephone, and cable television, shall be located underground throughout the subdivision or land development. Whenever existing utility facilities (other than major distribution lines) are located above ground, except when existing with public roads rights-of-ways, they shall be removed and placed underground. Easements centered on rear lot lines shall be provided for utilities, private and public, and such easements shall be at least 10 feet wide. When topographical or other conditions are such as to make impractical the inclusion of utilities along the rear lot lines of a subdivision, lot, or land development site, perpetual unobstructed easements at least 10 feet in width shall be provided along side lot lines with satisfactory access.

§1-31 OVERSIZING OF IMPROVEMENTS AND UTILITIES

The subdivider or land developer shall construct such oversized improvements and utilities that the Town determines are necessary, provided that the subdivider or land developer shall not be obligated for the additional cost of improvements and utilities that are not uniquely required for that development, and provided the subdivider agrees to a proposal by the Town to share in the cost arrangements for over-sizing improvements and utilities. A formula may be developed by the Town to provide for a sharing of the cost of other improvements needed to serve the subdivision or land development when certain of the improvements are necessary to serve future subdivisions or developments in the vicinity.

§1-32 ADMINISTRATION

§1-32.1 Fees. The fees for various applications required by this Ordinance shall be as set by separate resolution of the local governing body. Any fees incurred by the Town in connection with the review of any plats submitted shall be borne by the applicant.

§1-32.2 Additional Specifications. The Land Use Officer is hereby authorized to prepare and recommend standard drawings and constructions specifications for private and public improvements not specified in this ordinance. Upon their adoption by the local governing body, they shall become mandatory.

§1-32.3 Variances. Upon application, a variance to the terms of this ordinance may be granted only by the Town Council. The Town Council shall base its required findings upon the particular evidence presented to it in each specific case where the property owner can show that:

- (a) The strict application of the terms of this Ordinance would effectively prohibit or unreasonably restrict utilization of the property because of:
 - 1) There are extraordinary and exceptional conditions pertaining to the particular piece of property in question because of its size, shape, or topography;
 - 2) Such conditions are peculiar to the particular piece of such property involved;
 - 3) Such conditions were not imposed by the action or will of the owner of the property;
 - 4) The application of the Ordinance to the particular piece of property would create an unnecessary hardship. Such hardship does not include financial hardship in that if the variance were granted, the applicant could receive a higher rate of financial return on the use of the property and that without the variance, a lesser but still reasonable return could be realized; and
 - 5) Relief, if granted, would not cause substantial detriment to the public good or impair the purposes and intent of this Ordinance.
- (b) The granting of such variance will alleviate a clearly demonstrable hardship approaching confiscation, as distinguished from a special privilege or convenience sought by the applicant.
- (c) The condition or situation of the property which gives rise to the need for such variance is not of so general or recurring a nature as to make reasonably practicable the formulation of a general regulation to be adopted as an amendment to this Ordinance.

The applicant for a variance shall bear the burden of producing evidence to establish that the requested variance satisfies the standards for a variance. The Town Council may impose such conditions and restrictions upon the location, character and other features of the proposed structure or use as it may deem necessary in the public interest and may require a guarantee or bond to ensure that the conditions imposed are being and will continue to be complied with. Failure to comply with any such conditions and restrictions shall constitute a violation of this Ordinance.

§1-32.4 Inspections. The Land Use Officer shall be authorized to inspect premises proposed for subdivision or land development, including any improvements within such subdivision or land development, to determine compliance with the requirements of this ordinance and other laws and regulations of Town. No person shall refuse entry or access to any person authorized to conduct inspections who presents appropriate credentials for same, nor shall any person obstruct, hamper or interfere with any such person while in the process of carrying out his official duties. The Land Use Officer is authorized to establish procedures for inspection of land development activity at various intervals in the development process, including without limitation inspection procedures for erosion control, the initiating of grading or land-disturbing activity, installation of on-site sewage disposal systems or sanitary sewer, installation of storm drainage pipe, detention, or other storm water facilities, and installation of street curbing and gutter, road sub-grade, base, or paving.

§1-32.5 Amendment. The Town Council may amend this ordinance in a manner consistent with Georgia law. Before enacting such amendment to this ordinance, the Planning Commission shall provide a recommendation on the proposed amendment. The Town Council shall hold a public hearing thereon, notice of which shall be published at least fifteen (15) days prior to such hearing in the Town's legal organ or a newspaper of general circulation in the County.

§1-32.6 Conflict with other Regulations. Whenever the regulations of this Ordinance require or impose more restrictive standards than are required in or under any other statutes or

ordinances, the requirements of this Ordinance shall govern. Whenever the provisions of any other statute or ordinance require more restrictive standards than are required by this Ordinance, the provisions of such statute or ordinance shall govern.

§1-33 ENFORCEMENT AND PENALTIES

§1-33.1 Generally. Any action or inaction which violates the provisions of this ordinance or the requirements of an approved site plan or permit may be subject to any or all of the enforcement actions and remedies described in this section.

§1-33.2 Stop Work Order. The Land Use Officer upon learning or discovering a violation of this ordinance or any approved site plan or permit issued pursuant to this ordinance may immediately issue a stop work order which shall be posted on the job site and mailed to the applicant shown on the permit or approved site plan. The stop work order shall remain in effect until the applicant or other responsible person has taken the remedial measures set forth in the notice of violation or has otherwise cured the violation or violations described therein, provided the stop work order may be withdrawn or modified to enable the applicant or other responsible person to take necessary remedial measures to cure such violation or violations.

§1-33.3 Notice of Violation. Prior to or concurrent with the issuance of a Stop Work Order, if the Land Use Officer determines that an applicant or other responsible firm, person or corporation has failed to comply with the terms and conditions of a permit, an approved site plan or the provisions of this ordinance, he shall issue a written notice of violation to such applicant or other responsible person. Where a person is engaged in activity covered by this ordinance without having first secured the appropriate permit there for, the notice of violation shall be served on the owner or the responsible person in charge of the activity being conducted on the site.

§1-33.4 Content of Notice of Violation. Notices of violation shall contain the following:

- (a) The name and address of the owner or the applicant or the responsible person;
- (b) The address or other description of the site upon which the violation is occurring;
- (c) A statement specifying the nature of the violation;
- (d) A description of the remedial measures necessary to bring the action or inaction into compliance with the permit, the approved site plan or this ordinance and the date for the completion of such remedial action, and a date set forth for completion of remedial measures, after which further enforcement action will be taken; and
- (e) A statement of the penalty or penalties that may be assessed against the person to whom the notice of violation is directed.

§1-33.5 Failure of Remedial Measures. In the event the remedial measures described in the notice of violation have not been completed by the date set forth for such completion in the notice of violation, any one or more actions or penalties described in this section as appropriate may be taken or assessed against the person to whom the notice of violation was directed.

§1-33.6 Suspension, Revocation or Modification of Permit. The Land Use Officer may suspend, revoke or modify any permit or approval authorizing an activity or land development project. A suspended, revoked or modified permit may be reinstated after the applicant or other responsible person has taken the remedial measures set forth in the notice of violation or has otherwise cured the violations described therein, provided such permit may be reinstated (upon such conditions as the enforcement officer may deem necessary) to enable the applicant or other responsible person to take the necessary remedial measures to cure such violations.

§1-33.7 Withholding of Utility Service. The Land Use Officer may request or direct any utility service provider to withhold utility service to any property on which a violation has occurred.

§1-33.8 Citation. The Land Use Officer shall have authority to issue citations and to prosecute violations before a court of competent jurisdiction. Violations of ordinances in the Town may be tried upon citation with or without a prosecuting attorney as well as upon accusations.

§1-33.9 Civil Penalties. Any person, firm or corporation violating, neglecting or refusing to comply with any of the provisions of this ordinance, or any site plan approval or permit issued pursuant to this ordinance shall be guilty of a misdemeanor. Any violation of any such provision of this ordinance shall be punished by a fine not exceeding \$1,000.00 or by imprisonment not exceeding six months, or by a combination of such punishments. Each day any violation of this ordinance shall continue shall constitute a separate offense.

§1-34 ADOPTION AND EFFECTIVE DATE

This ordinance is hereby adopted this 20th day of August, 2007, and shall be effective immediately upon its adoption, the public welfare demanding it.

TOWN COUNCIL

Mayor

ATTEST:

Town Clerk

APPROVED AS TO LEGAL FORM AND SUFFICIENCY:

Town Attorney